



INDEX OF TEXAS ARCHAEOLOGY

Open Access Gray Literature from the Lone Star State

Volume 2015

Article 34

2015

The Stover Lake Site (41BW8) on the lower Sulphur River, Bowie County, Texas

Timothy K. Perttula

Heritage Research Center, Stephen F. Austin State University

Follow this and additional works at: <https://scholarworks.sfasu.edu/ita>



Part of the [American Material Culture Commons](#), [Archaeological Anthropology Commons](#), [Environmental Studies Commons](#), [Other American Studies Commons](#), [Other Arts and Humanities Commons](#), [Other History of Art, Architecture, and Archaeology Commons](#), and the [United States History Commons](#)

Tell us how this article helped you.

This Article is brought to you for free and open access by the Center for Regional Heritage Research at SFA ScholarWorks. It has been accepted for inclusion in Index of Texas Archaeology: Open Access Gray Literature from the Lone Star State by an authorized editor of SFA ScholarWorks. For more information, please contact cdsscholarworks@sfasu.edu.

The Stover Lake Site (41BW8) on the lower Sulphur River, Bowie County, Texas

Creative Commons License



This work is licensed under a [Creative Commons Attribution-NonCommercial 4.0 International License](https://creativecommons.org/licenses/by-nc/4.0/)

The Stover Lake Site (41BW8) on the lower Sulphur River, Bowie County, Texas

Timothy K. Perttula

INTRODUCTION

The Stover Lake site (41BW8) is an ancestral Caddo cemetery and habitation site on a natural alluvial rise in the Sulphur River floodplain, about 1.6 km east of the Lake Wright Patman dam (Figure 1). In 1961-1962, several collectors excavated at least 19 Caddo burials at the site and also gathered a collection of sherds from habitation contexts. Notes on the burials and their funerary offerings were provided by the collectors to the Texas Archeological Research Laboratory at The University of Texas at Austin (TARL), and 390 ceramic sherds and one stone gorget from non-burial contexts were donated to TARL by one of the collectors, Janson L. McVay.

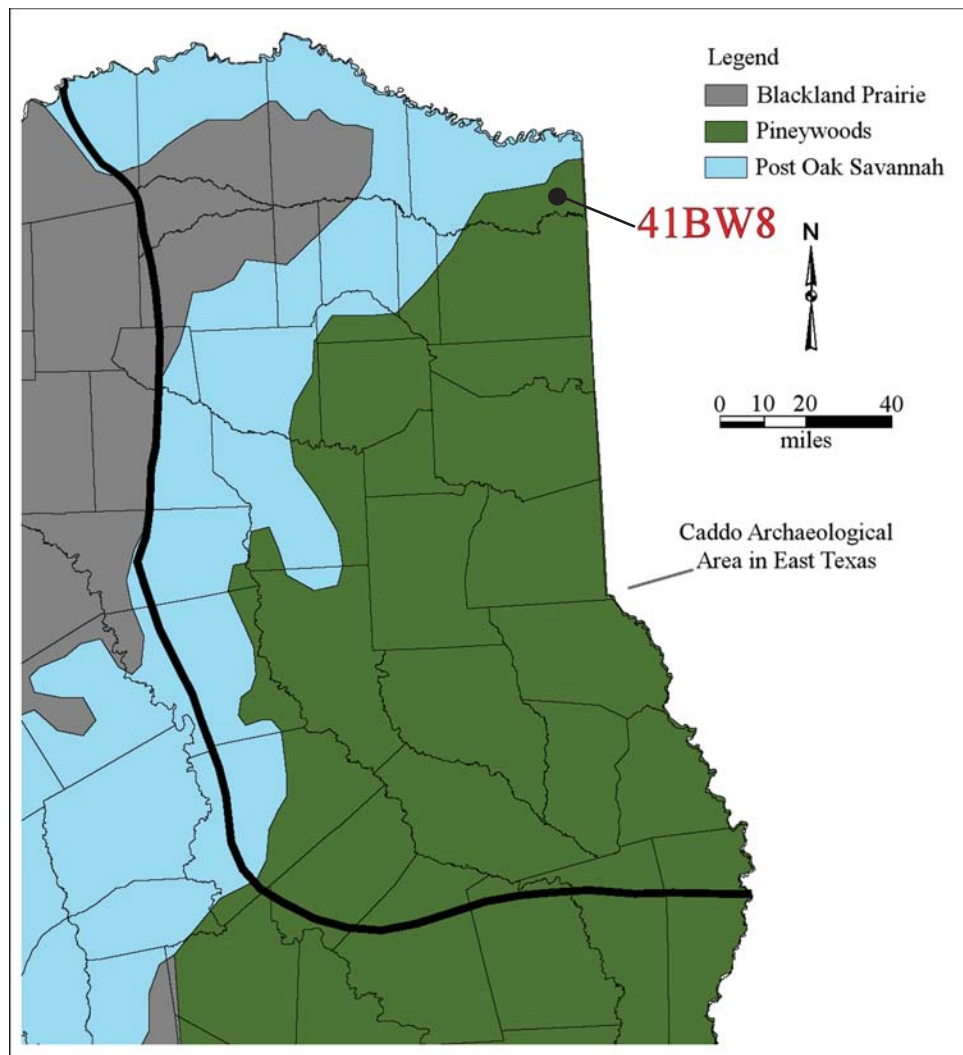

Figure 1. The location of the Stover Laker site (41BW8) in the East Texas Pineywoods.

BURIAL FEATURES

There are drawings of several of the burial features at the Stover Lake site, but no overall map that shows the relationship of the burial features excavated by Chester Paxton (Burials 1-6), Janson L. McVay (Burials S1-S4), and Roger McVay (Burials S8-S16). There is no information in TARK files on burials S5-S7.

In general, the burial features at the Stover Lake site were placed in an extended supine position in grave pits that were oriented north-south, with the head of the deceased at the southern end of the grave, facing north (Table 1). One burial (S1) was oriented northwest-southeast, but the head of the deceased still faced north. Burial S8 was buried in a semi-flexed position, however, with the head of the deceased facing west. Although no human remains were recovered from any of the graves, their size and depth suggests they are the graves of Caddo adult men and women. Burial features ranged from ca. 46-147 cm in depth.

Table 1. Burial features at the Stover Lake site.

Burial No.	Depth (cm bs)	Vessels	Pipes	Shell Pendants	Shell beads	Other Offerings
1	81	2	—	—	—	—
2	122	4	—	—	—	—
3	114	3	1	—	—	—
4	114	2	—	—	—	1 bone awl
5	114	1	1	—	—	—
6	81	2	—	—	—	—
S1	46	—	—	—	—	—
S2	122	1	—	—	—	—
S3	N/A	2	—	—	—	—
S4	N/A	—	—	—	—	—
S8	76	2	—	—	—	—
S9	99	1	—	—	—	—
S10	86	1	—	—	—	—
S11	137	2	1	2	13	—
S12	147	2	—	—	5	1 possible wood bow fragment
S13	107	1	1	—	—	—
S14	107	5	—	—	—	4 Hayes arrow points, 1 Alba arrow point
S15	112	2	—	—	—	—
S16	112	1	—	—	—	—
Totals	—	34	4	2	18	1 bone awl, 5 arrow points, 1 possible wood bow fragment

Two of the burial features—S13 and S16—had one or two post holes visible in the floor of the graves. The post holes may represent the remains of burial furniture erected in or over the grave, or post holes from unrelated habitation structural features.

FUNERARY OFFERINGS

Funerary offerings in the 19 burial features at the Stover Lake site include 34 ceramic vessels (from 17 of the burials), a mean of 1.8 vessels per burial (Table 1), four clay pipes (from four of the burials), two plain marine shell pendants from one burial, and 18 marine shell beads from two burials. One burial also had a bone awl and another had five arrow points, and Burial S12 had a 107 x 2 cm long and wide wood fragment by the deceased's right leg; this wood fragment may have been the remnants of a wood bow; the type of wood was not mentioned in the collector's notes.

The marine shell beads in burials S11 and S12 are barrel-shaped. Those in Burial S11 were at the right wrist, while those from Burial S12 were between the head and shoulder.

The arrow points in Burial S14 include four of the Hayes type and one Alba point (see Turner et al. 2011:177-197). Both types are found in ca. A.D. 1200-1400 burial features throughout East Texas.

Ceramic Vessels

In Burials 1-6, identifiable vessels include Barkman Engraved vessels (n=2) from Burials 2 and 3, Haley Engraved vessels (n=2) in Burials 3 and 6, a Brushed-Incised jar in Burial 3, and Pease Brushed-Incised jars (n=2) in Burials 1 and 6. There was also a plain bottle in Burial 1; it had green pigment stains on its exterior vessel surface. Including the information on the clay pipes in Burials 3 and 5, these burials suggest use of the cemetery in the latter part of the 14th century and into the 15th century A.D.

The three vessels in Burials S1-4 include a diagonal incised-zone punctated jar in Burial S2, a possible Nash Neck Banded jar in Burial S3, and a bottle with vertical engraved lines in Burial S3. This bottle had a red pigment rubbed in the engraved lines.

In Burial S8, one vessel is a Nash Neck Banded jar, while the other is an engraved compound bowl (with a scalloped lip) with horizontal engraved lines on the upper rim panel and diagonal opposed engraved lines on the lower rim panel (Figure 2). Burial S9 had a small Moore Noded bowl (Figure 3) with applied nodes covering the exterior vessel surface. The one vessel in Burial S10 is an inverted rim carinated bowl,

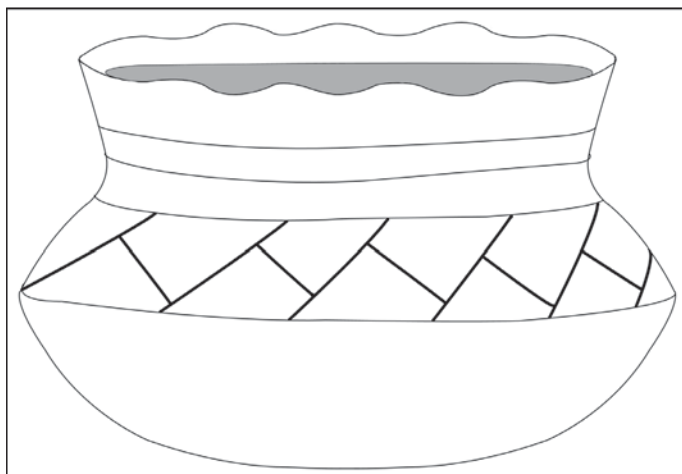

Figure 2. Engraved compound bowl, Burial S8-1.

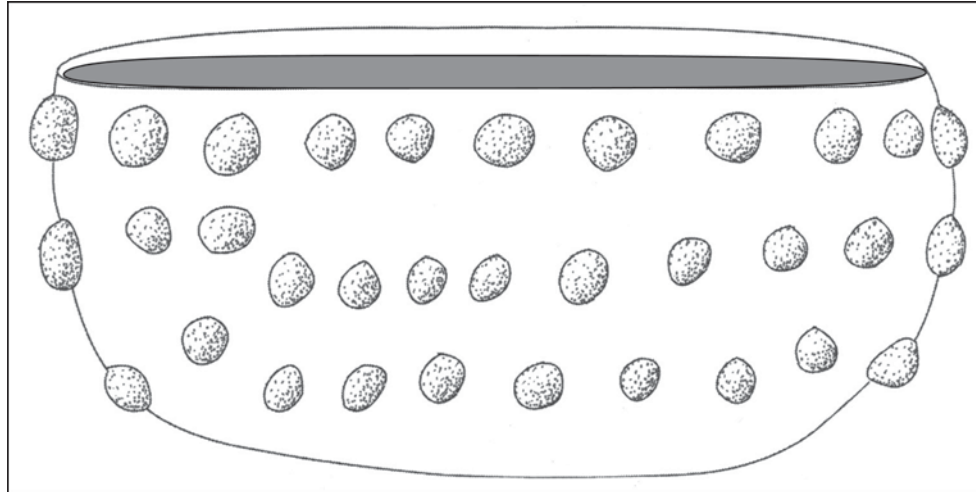

Figure 3. Moore Noded bowl, Burial S9-1.

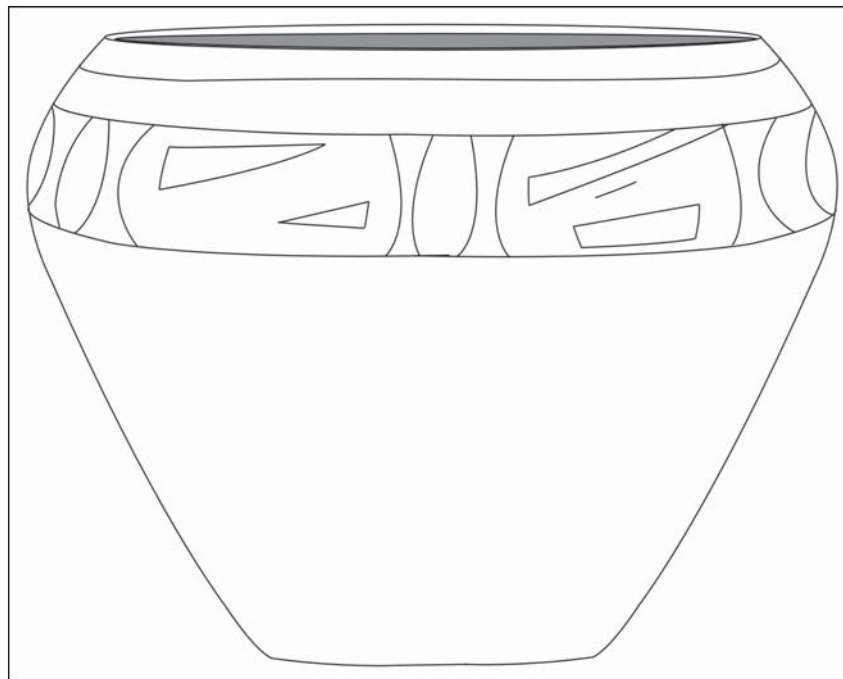

Figure 4. Possible Simms Engraved carinated bowl, Burial S10-1.

possibly a Simms Engraved vessel with panels created by brackets that have upper and lower triangular elements (Figure 4).

Burial S11 has a possible Hatchel Engraved bottle with oval panels filled with circle, a six-pointed hatched star, and open square elements (Figure 5). The panels are divided by brackets with negative ovals. There is a single horizontal engraved line encircling the bottom of the bottle neck, and this line has a series of hatched engraved pendant triangles. The other vessel in Burial S11 is a brushed-punctated jar (Figure 6).

The first vessel in Burial S12 is a small-mouthed bottle that had been placed by the head of the deceased. The bottle has two vertical rows of large applied nodes on the vessel body as well as unique engraved decorative elements (Figure 7). These consist of sets of horizontal engraved lines below the rim and above the vessel base, large triangles and curvilinear lines, and a series of narrow vertical to diagonal hatched zones.

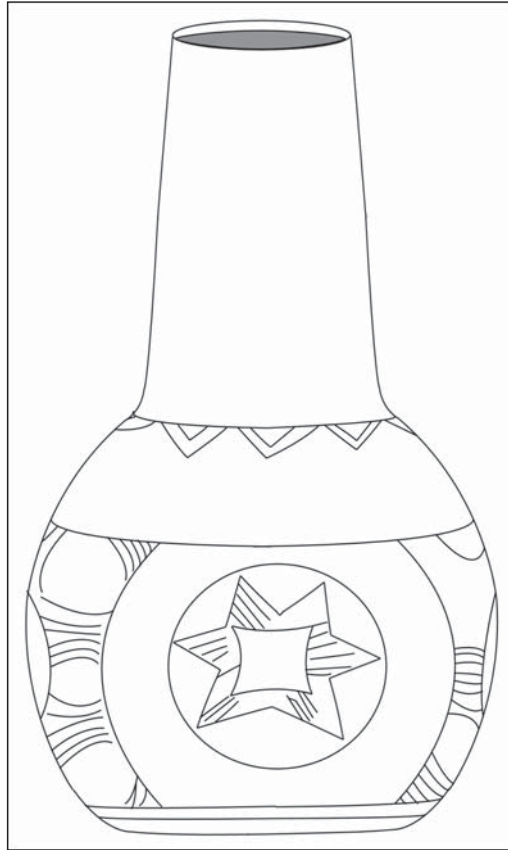

Figure 5. Possible Hatchel Engraved bottle, Burial S11-1.

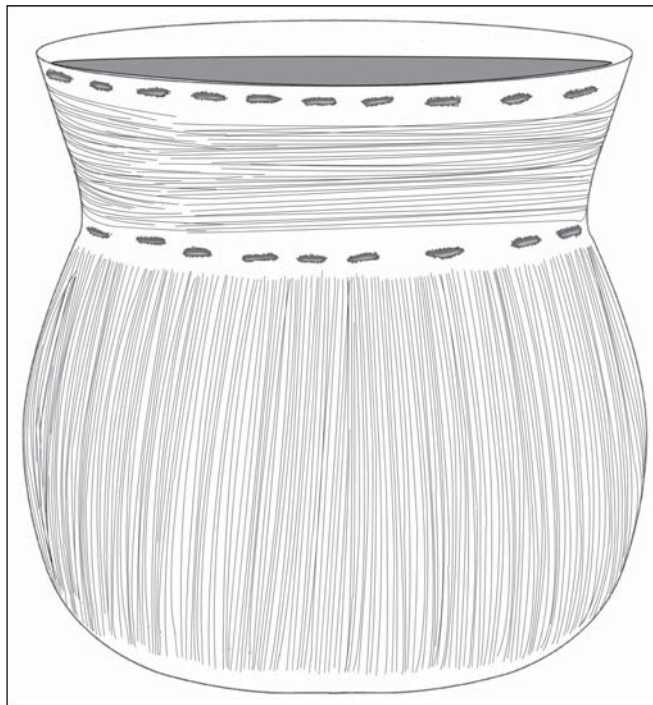

Figure 6. Brushed-punctated jar, Burial S11-3.

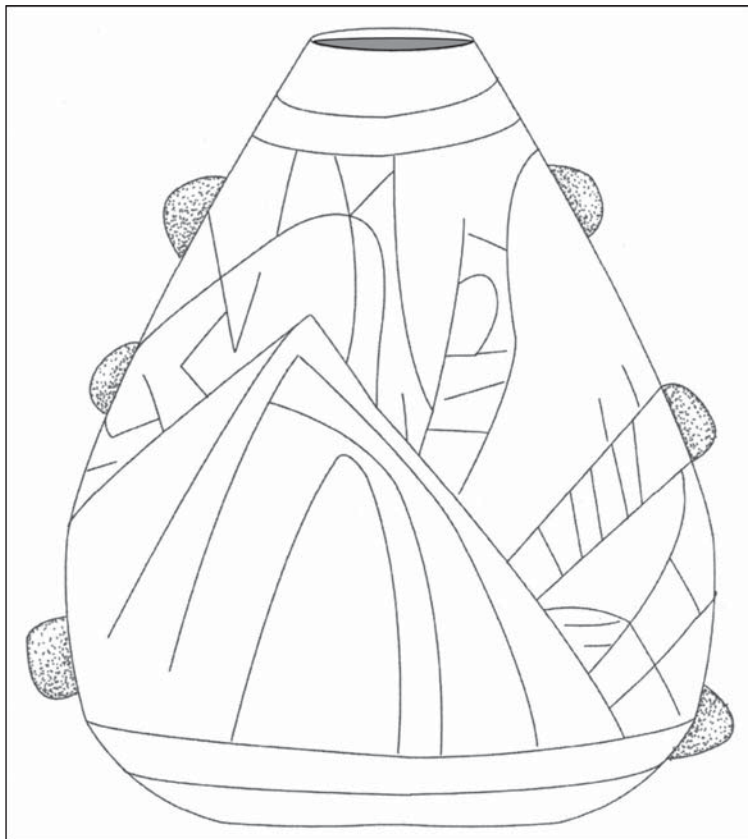

Figure 7. Engraved-applied bottle, Burial S12-1.

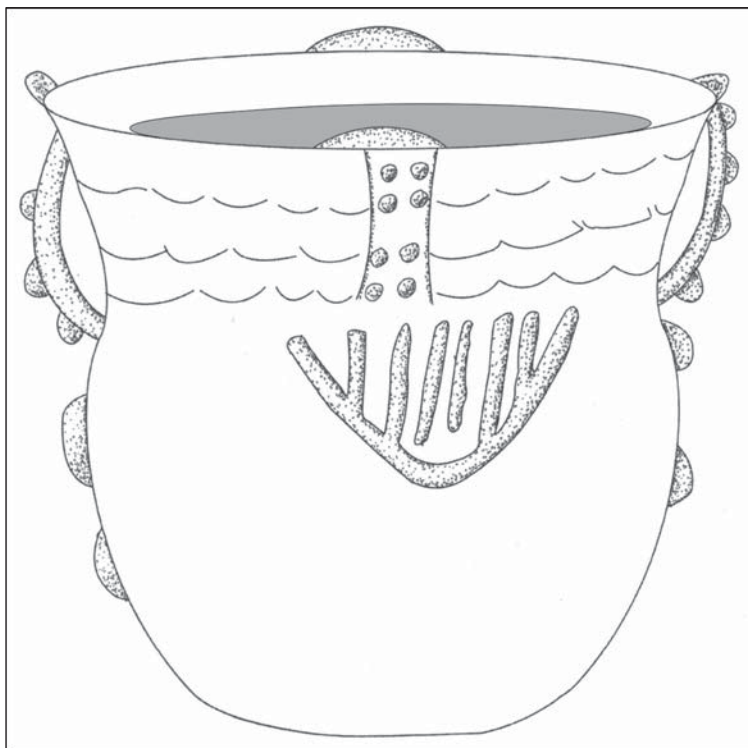

Figure 8. Nash Neck Banded jar, Burial S12-2.

The second vessel in the burial is a Nash Neck Banded jar with applied strap handles, vertical applied nodes on the body, and applied triangle elements on the upper vessel body (Figure 8).

The one vessel in Burial S13 is an engraved bottle that had been placed above the head of the deceased; a red pigment had been rubbed in the engraved design. The bottle, likely of the Hatchel Engraved type, has panels with upper and lower triangle-shaped elements, and the panels have vertical or curvilinear lines with tick marks (Figure 9). Between the panels are large bracket elements with short curvilinear and rectilinear elements.

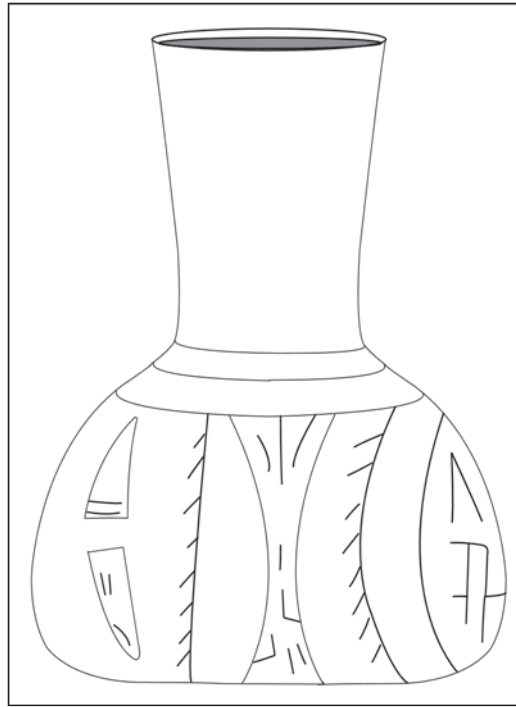

Figure 9. Possible Hatchel Engraved bottle, Burial S13-1.

The ceramic vessels from Burial S14 are stylistically distinctive. The first vessel, by the head, is a Hickory Engraved bottle; there are tick marks on the lowermost horizontal engraved line on the upper vessel body (Figure 10). The second vessel is a Pease Brushed-Incised jar (Figure 11), while the third is a jar with horizontal incised lines on the rim as well as a row of linear tool punctations (Figure 12). The fourth vessel in Burial 14 may be a Haley Complicated Incised jar (Figure 13), with horizontal incised lines on the rim, rows of linear punctations on the vessel body, and a curvilinear applied fillet across the vessel body (see Suhm and Jelks 1962:59). The last vessel is a Handy Engraved carinated bowl with rectilinear scroll elements filled with excised punctations (Figure 14).

Two ceramic vessels comprise the funerary offerings in Burial S15. The first is a plain bottle that had been placed by the head of the deceased (Figure 15a), and the second is a Barkman Engraved carinated bowl (Figure 15b). This vessel has two horizontal engraved zones with short excised punctations and spurs with excised punctations.

Only one ceramic vessel was placed in Burial S16 at the Stover Lake site. It is a everted rim jar with rows of tool punctations on the rim panel (Figure 16).

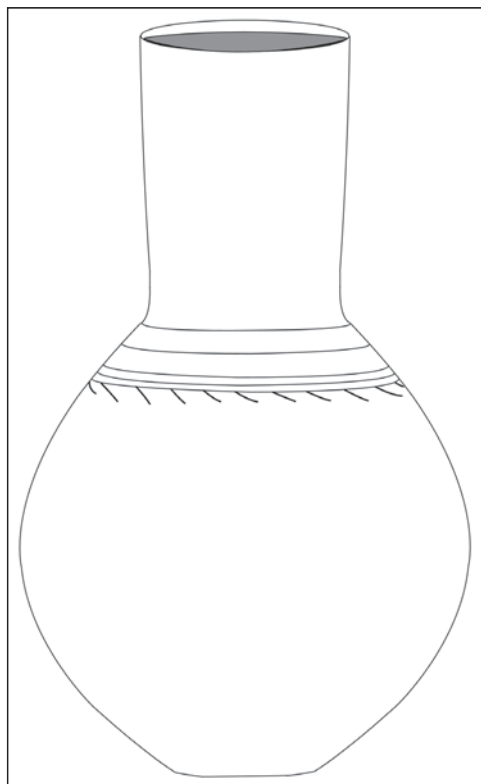

Figure 10. Hickory Engraved bottle, Burial S14-1.

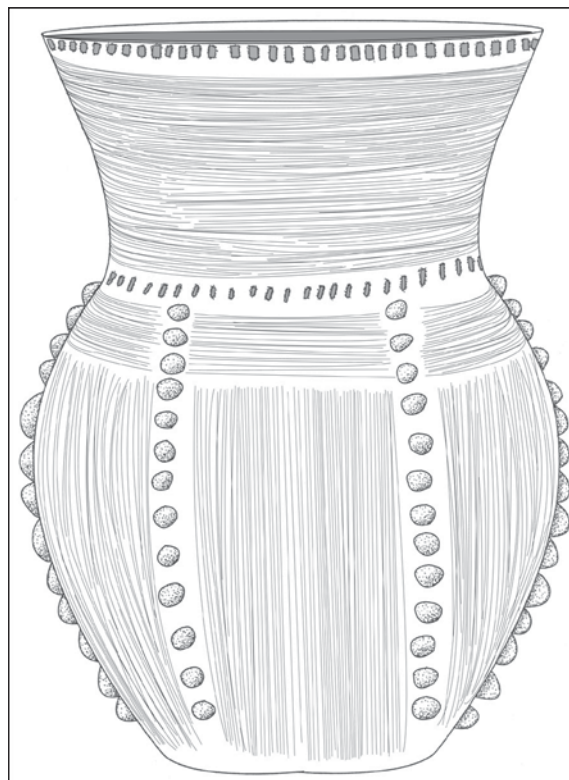

Figure 11. Pease Brushed-Incised jar, Burial S14-2.

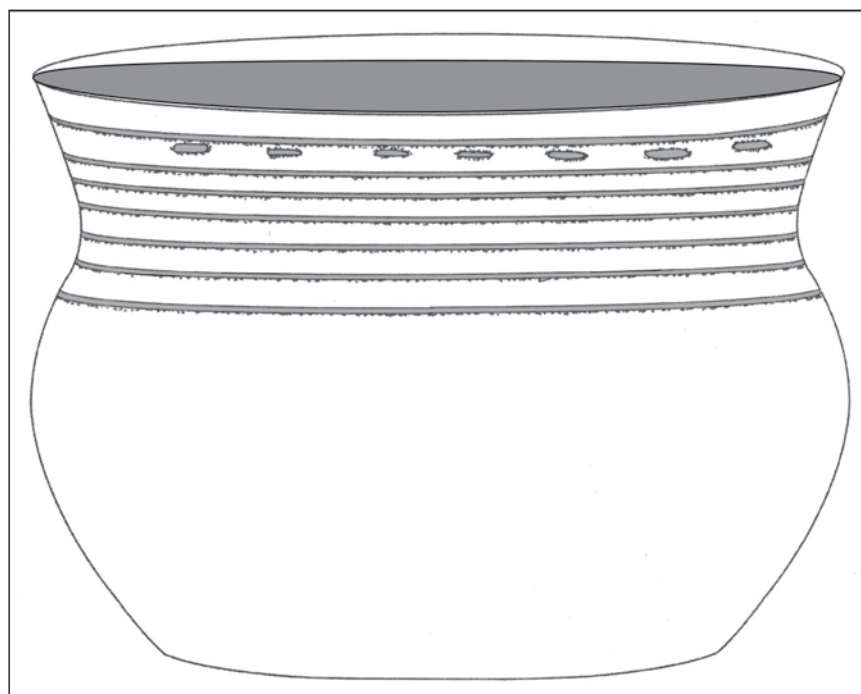

Figure 12. Incised-punctated jar, Burial S14-3.

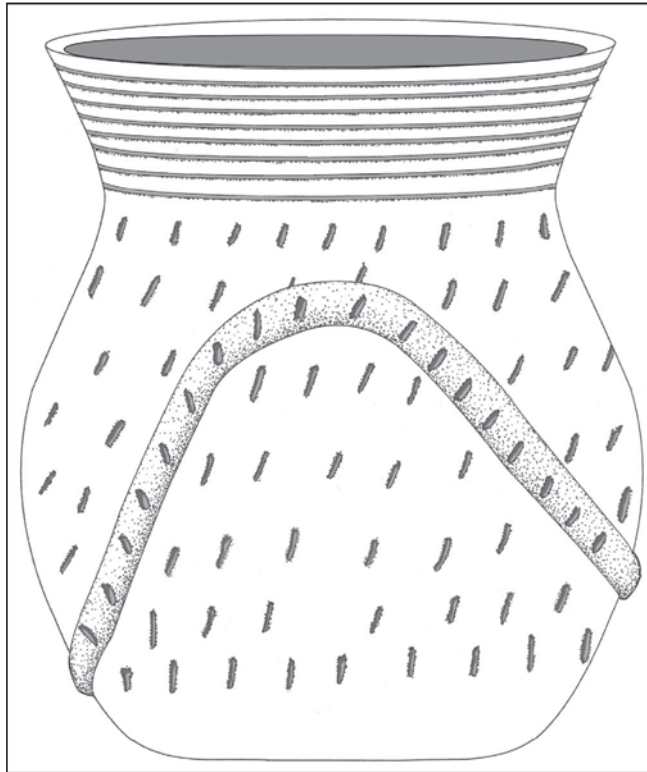

Figure 13. Possible Haley Complicated Incised jar, Burial S14-4.

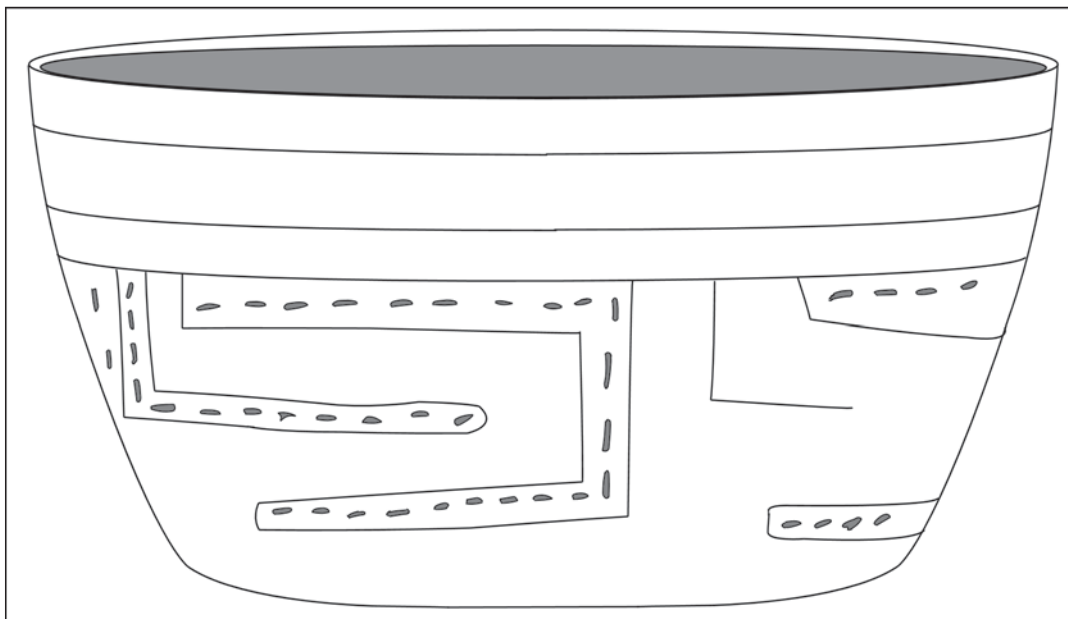

Figure 14. Handy Engraved carinated bowl, Burial S14-5.

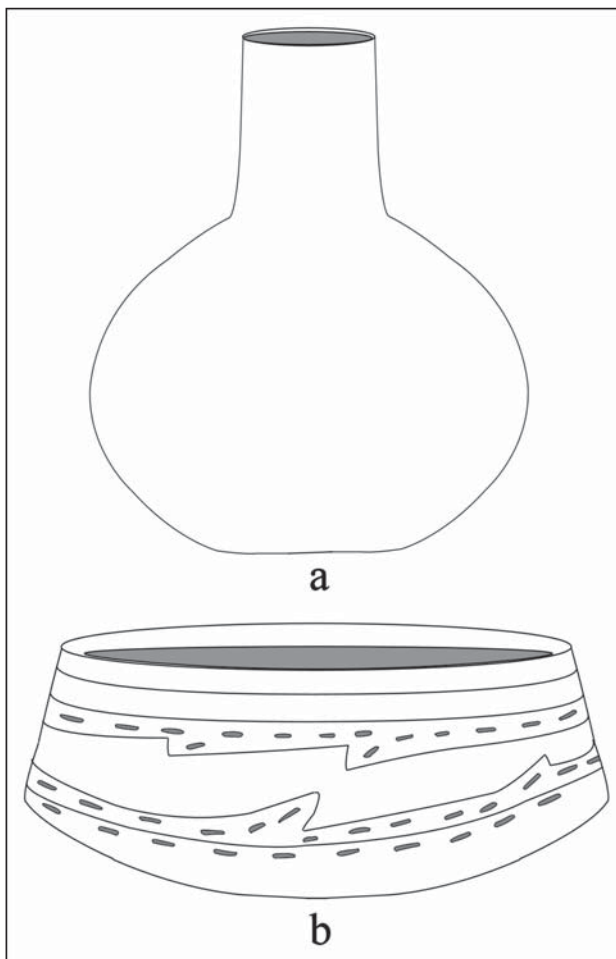

Figure 15. Ceramic vessels from Burial S15: a, plain bottle, S15-1; b, Barkman Engraved carinated bowl, S15-2.

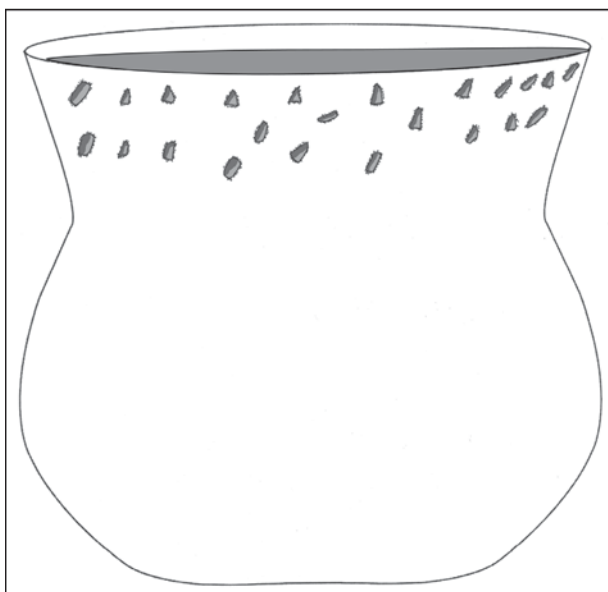

Figure 16. Punctated jar, Burial S16-1.

Clay Pipes

Pipes from Burials 3 and 5 were long-stemmed Red River, *var. Haley* style pipes (see Hoffman 1967:10 and Figure 5). These pipes are found in Middle Caddo period contexts. The other two pipes are elbow pipes, including an equal arm elbow pipe from Burial S13 (Figure 17b) and an elbow pipe with a short projecting distal stem from Burial S11 (Figure 17a-a'). Both of these elbow pipe styles are associated with post-A.D. 1400 Caddo occupations.

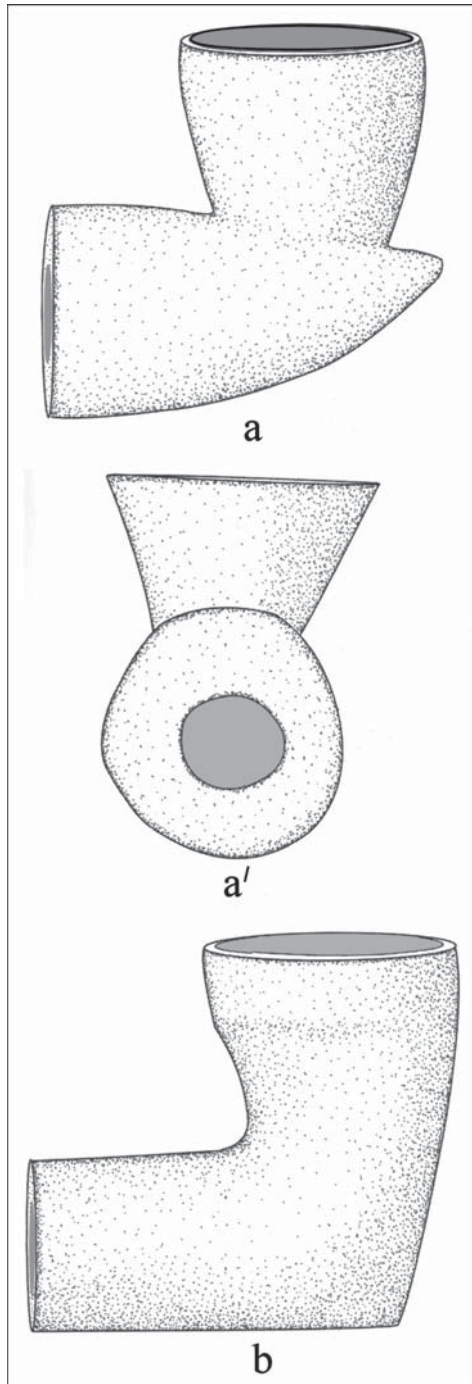

Figure 17. Elbow pipes from the Stover Lake site: a-a', Burial S11; b, Burial S13.

CERAMIC SHERDS

Janson McVay donated 390 Caddo ceramic sherds from the Stover Lake site to TARL. These sherds include 250 plain rim, body, and base sherds and 140 sherds with decorative elements. The intra-site contexts of these sherds are not known.

The sherds from utility ware (with wet paste decorations) vessels (n=106) include those with brushing (n=27, 25.5 percent of the utility ware assemblage), brushed-punctated (n=7, 6.6 percent, likely from Pease Brushed-Incised vessels), brushed-incised (n=11, 10.4 percent, likely from Pease Brushed-Incised vessels), incised-punctated (n=15, 14.2 percent), punctated (n=7, 6.6 percent), incised (n=26, 24.5 percent), pinched (n=3, 2.8 percent), and applied (n=10, 9.4 percent) elements. Sherds with brushed decorative elements, either as the sole decoration or in combination with incised lines or punctations, comprise 42.5 percent of the utility wares, pointing to many of the utility ware sherds deriving from a post-A.D. 1400 Caddo occupation. Other Late Caddo utility wares from the site include a Cass Applied sherd as well as a Sinner Linear Punctated sherd.

Other utility wares are from an earlier occupation at the site, one dating perhaps before A.D. 1200. These sherds include two incised sherds from Dunkin Incised vessels and six incised-punctated sherds from Crockett Curvilinear Incised or Pennington Punctated-Incised vessels.

The fine ware sherds (n=34) from the Stover Lake site are from engraved vessels (n=33) and a red-slipped (n=1) vessel. Seven of the engraved sherds are from bottles, while two sherds that could be identified to type are from post-A.D. 1400/1500 Barkman Engraved (n=2) and Belcher Engraved (n=3) vessels.

GROUND STONE ARTIFACTS

Also in the TARL collections from the Stover Lake site is a small polished stone gorget (Figure 18). The gorget has four equally-spaced drilled holes; their purpose is unknown.

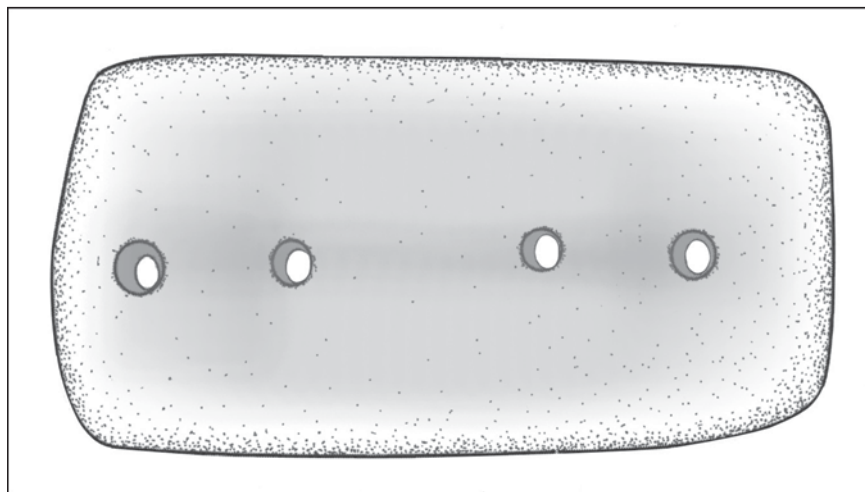

Figure 18. Stone gorget from the Stover Lake site.

SUMMARY AND CONCLUSIONS

The Stover Lake site (41BW8) on the lower Sulphur River in the East Texas Pineywoods is an ancestral Caddo habitation site and cemetery that was investigated by several collectors in 1961-1962. At least 19 Caddo burials were excavated at the site by the collectors, and a large sample of Caddo ceramic sherds were donated by the collectors to TARL.

The burials were apparently that of adults in grave pits oriented north-south, with the head of the deceased facing north, and the deceased were accompanied by a range of funerary offerings, including ceramic vessels, clay pipes, marine shell pendants and beads, a bone awl, arrow points, and wood fragments from a possible wood bow. The funerary offerings in the burials suggest that the cemetery at the Stover Lake site was used by Caddo peoples for several generations, perhaps not continuously, from as early as the 14th century (during the Middle Caddo period Haley phase) to most commonly after ca. A.D. 1400 to the early-mid-16th century (during the Late Caddo period Texarkana phase). Miscellaneous ceramic sherds from likely habitation contexts at the site are also primarily from a post-A.D. 1400 Caddo occupation, but several decorated utility ware sherds suggest the site may have been first settled by Caddo peoples by ca. A.D. 1200, if not earlier.

ACKNOWLEDGMENTS

I thank Lance Trask for preparing the figures for this article.

REFERENCES CITED

- Hoffman, M. P.
1967 Ceramic Pipe Style Chronology along the Red River Drainage in Southwestern Arkansas. *The Arkansas Archeologist* 8(1):4-14.
- Jelks, E. B.
1961 *Excavations at Texarkana Reservoir, Sulphur River, Texas*. River Basin Survey Papers No. 21. Bureau of American Ethnology, Smithsonian Institution, Washington, D.C.
- Perttula, T. K.
2014 *The Mitchell Site (41BW4): An Ancestral Caddo Settlement and Cemetery on McKinney Bayou, Bowie County, Texas*. Special Publication No. 32. Friends of Northeast Texas Archaeology, Austin and Pittsburg.
- Suhm, D. A. and E. B. Jelks (editors)
1962 *Handbook of Texas Archeology: Type Descriptions*. Special Publication No. 1, Texas Archeological Society, and Bulletin No. 4, Texas Memorial Museum, Austin. Reprinted in 2009, Gustav's Library, Davenport, Iowa.
- Turner, E. S., T. R. Hester, and R. L. McReynolds
2011 *Stone Artifacts of Texas Indians*. 3rd Edition. Taylor Trade Publishing, Lanham, Maryland.