



# INDEX OF TEXAS ARCHAEOLOGY

*Open Access Gray Literature from the Lone Star State*

---

Volume 2017

Article 59

---

2017

## Documentation of Ancestral Caddo Ceramic Vessels from the Knight's Bluff (41CS14) and Sherwin (41CS26) Sites, Cass County, Texas

Timothy K. Perttula

*Heritage Research Center, Stephen F. Austin State University*

Follow this and additional works at: <https://scholarworks.sfasu.edu/ita>



Part of the [American Material Culture Commons](#), [Archaeological Anthropology Commons](#), [Environmental Studies Commons](#), [Other American Studies Commons](#), [Other Arts and Humanities Commons](#), [Other History of Art, Architecture, and Archaeology Commons](#), and the [United States History Commons](#)

Tell us how this article helped you.

---

This Article is brought to you for free and open access by the Center for Regional Heritage Research at SFA ScholarWorks. It has been accepted for inclusion in Index of Texas Archaeology: Open Access Gray Literature from the Lone Star State by an authorized editor of SFA ScholarWorks. For more information, please contact [cdsscholarworks@sfasu.edu](mailto:cdsscholarworks@sfasu.edu).

---

## Documentation of Ancestral Caddo Ceramic Vessels from the Knight's Bluff (41CS14) and Sherwin (41CS26) Sites, Cass County, Texas

Creative Commons License



This work is licensed under a [Creative Commons Attribution-NonCommercial 4.0 International License](https://creativecommons.org/licenses/by-nc/4.0/)

---

# Documentation of Ancestral Caddo Ceramic Vessels from the Knight's Bluff (41CS14) and Sherwin (41CS26) Sites, Cass County, Texas

*Timothy K. Perttula*

---

## Introduction

A number of years ago, Perttula et al. (2009) documented a variety of funerary objects through a Native American Graves Protection and Repatriation Act (NAGPRA) grant awarded to the Caddo Nation of Oklahoma. These were from ancestral Caddo sites on U.S. Army Corps of Engineers, Fort Worth District lands in East Texas, including funerary objects from the Knight's Bluff and Sherwin sites at Lake Wright Patman in the Sulphur River basin (Perttula et al. 2009) (Figure 1). These NAGPRA materials are held at the Texas Archeological Research Laboratory at The University of Texas at Austin (TARL).

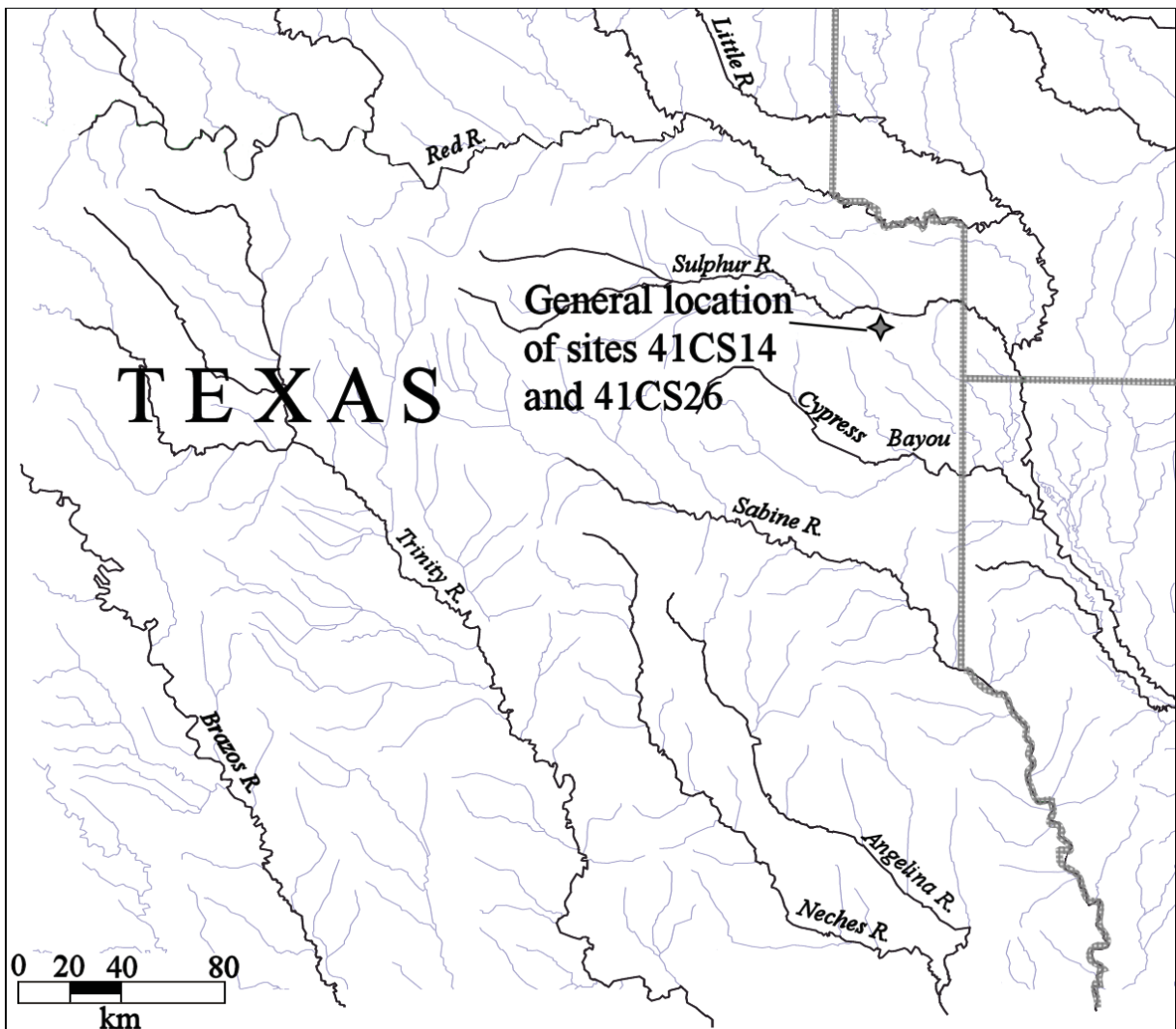

Figure 1. Location of the Knight's Bluff (41CS14) and Sherwin (41CS26) sites in East Texas.

At that time, only a few ceramic vessel funerary objects were made available for NAGPRA documentation purposes, including only three ceramic vessels from Burial 4 at the Knight's Bluff site, and six vessels from Burials 4 and 6 at the Sherwin site. The remainder of the ceramic vessel funerary objects from these two sites (n=16 vessels from Knight's Bluff and n=13 vessels from the Sherwin site), plus one vessel from general Lake Wright Patman contexts, either from Knight's Bluff or the Sherwin site, have recently been documented, and they are discussed in the remainder of this article.

### **Ceramic Vessel Analysis**

As with other ancestral Caddo ceramic vessel documentation studies completed of ceramic assemblages from East Texas sites in recent years, the following consistent set of attributes were employed in the study and documentation of the ceramic vessels from this collection from the Knight's Bluff and Sherwin sites:

Non-plastics: Deliberate and indeterminate materials in the paste (Rice 1987:411), including a variety of tempers (i.e., grog or crushed sherds, bone, hematite, and shell, as well as combinations of different temper inclusions) and "particulate matter of some size." The grog, bone, hematite, or shell appears to have been deliberately added to the paste as tempers. The bone or shell used for temper had been burned and calcined, then crushed, before it was added to the paste.

Vessel Form: Vessel form categories include open containers (bowls of several sizes, including effigy bowls, carinated bowls, and compound bowls) and restricted containers, including jars and bottles, as well as plates. As restricted containers, jars allow access by hand, but bottles do not (Brown 1996:335). Other form attributes that were recorded include the rim profile (outflaring or everted, vertical or standing, and inverted), lip profile (rolled to the exterior, rounded, flat, or thinned), and base shape (circular or square, and flat or rounded).

Core Colors: Observations on ceramic cross-section colors permit consideration of oxidation patterns (Teltser 1993:Figure 2a-h), and thus the conditions under which the vessel was fired and then cooled after firing. Comments are included for these attributes on the presence and location of fire-clouding, sooting or smudging from cooking use (Skibo 1992), and the preservation of any charred organic remains.

Wall Thickness: Thickness was recorded in millimeters, using a vernier caliper, at the lip, along the rim, at several points along the body, and at the base when possible (only for the vessels that were not complete).

Interior and Exterior Surface Treatment: The primary methods of finishing the surface of the vessels includes either smoothing, burnishing, and polishing (Rice 1987:138). Brushing, while a popular method of roughening the surface (particularly the body) of large and small Middle (ca. A.D. 1200-1450) and Late Caddo (ca. A.D. 1450-1680) period cooking jars in several parts of the Caddo area, is here considered a decorative treatment rather than solely a functional surface treatment (cf. Rice 1987:138), although not all Caddo ceramic analysts treat brushing as a decorative treatment. Smoothing creates "a finer and more regular surface...[and] has a matte rather than a lustrous finish" (Rice 1987:138). Burnishing, on the other hand, creates an irregular lustrous finish marked by parallel facets left by the burnishing tool (perhaps a pebble or bone). A polished surface treatment is marked by a uniform and highly lustrous surface finish, done when the vessel is dry, but without "the pronounced parallel facets produced by burnishing leather-hard clay" (Rice 1987:138).

The application of a hematite-rich clay slip (Ferring and Perttula 1987), either red or black after firing in an oxidizing or reducing (i.e., low-oxygen) environment, is another form of surface treatment noted in many East Texas assemblages, and the frequency of red-slipped vessels is a notable characteristic of some vessel assemblage. On these vessels, the clay slip is more frequently applied on the vessel exterior, or on both surfaces, than on the interior surface, and then was either burnished or polished after it was leather-hard or dry.

Height and Orifice Diameter: These attributes, measured in centimeters, were recorded with a ruler.

Diameter at Bottom of Rim and Base Diameter: Also recorded in millimeters using a ruler, these attributes permit characterization of the overall contour and shape of the vessel.

Volume: With measurements of height and orifice diameter obtained from the vessels, as well as other measurements of size (i.e., base diameter and maximum body width), volumes were estimated by comparison with known vessel volumes of specific forms (i.e., carinated bowl, jar, bottle, compound bowl, and bowl) in many other recently documented Caddo vessel assemblages.

Base Diameter and Shape: these attributes were either measured in centimeters or by shape attributes: circular or square, and flat or round.

Decoration: Decorative techniques present in the vessel collections from Caddo sites in East Texas include engraving, incising, trailing, pinching, punctations, neck banding, brushing, and appliqué, and on certain vessels, combinations of decorative techniques (i.e., incised-punctated) created the decorative elements and motifs. Engraving was done with a sharp tool when the vessel was either leather-hard, or after it was fired, as were the tick marks often seen on vessels in these collections, while the other decorative techniques were executed with tools (trailing, incising, and punctation), by adding strips of clay to the wet body (appliqué), using frayed sticks or grass stems (brushing) dragged across the body surface, or fingernails (certain forms of punctations and pinching), when the vessel was wet or still plastic. Excising is considered a form of engraved decoration, where the clay is deliberately and closely marked/scraped and carved away with a sharp tool, usually to create triangular elements, tick marks, or excised punctations.

Use of Pigments: Another form of vessel decoration is the use of red (hematite or ochre) or white (kaolin clay) clay pigments that have been smeared or rubbed into the engraved lines of certain vessels.

Type: The kinds of ceramic types and defined varieties in the collections from East Texas sites follow Suhm and Jelks (1962), Schambach and Miller (1984), Fields et al. (2014), and for any post-1962 ceramic types: Perttula and Selden (2014).

### **Knight's Bluff Site Vessels**

Ten burials were excavated at the Knight's Bluff site by Jelks (1961) in two different small prehistoric cemeteries on either side of a Caddo structure (Jelks 1961:Figure 4). Another burial had been excavated at the site by I. B. Price, Jr. in 1931, and the vessel subsequently donated to the University of Texas. The kind and range of artifacts recovered in habitation and burial features at the Knight's Bluff site indicate that it was occupied during the Middle Caddo period (Cliff 1997; Perttula 1998).

SITE NAME OR SITE NUMBER: Knight's Bluff (41CS14)

VESSEL NO.: 25; excavated by I. B. Price, Jr. in 1931

VESSEL FORM: Jar

NON-PLASTICS AND PASTE: grog

RIM AND LIP FORM: Direct rim and flat lip

CORE COLOR: G (fired in a reducing environment and cooled in the open air)

INTERIOR SURFACE COLOR: dark grayish-brown

EXTERIOR SURFACE COLOR: brown; fire clouds on the body and base

WALL THICKNESS (IN MM): rim, 5.5 mm

INTERIOR SURFACE TREATMENT: none

EXTERIOR SURFACE TREATMENT: none

HEIGHT (IN CM): 13.3

ORIFICE DIAMETER (IN CM): 13.3

DIAMETER AT BOTTOM OF RIM OR NECK (IN CM): 13.1

BASE DIAMETER (IN CM) AND SHAPE OF BASE: 5.7 cm, circular and flat

ESTIMATED VOLUME (IN LITERS): 1.1

DECORATION (INCLUDING MOTIF AND ELEMENTS WHEN APPARENT): Plain

PIGMENT USE AND LOCATION ON VESSEL: none

TYPE AND VARIETY (IF KNOWN): Unidentified plain ware

SITE NAME OR SITE NUMBER: Knight's Bluff (41CS14)

VESSEL NO.: 6988, Burial 2

VESSEL FORM: Jar with four rim peaks

NON-PLASTICS AND PASTE: grog

RIM AND LIP FORM: Everted rim and rounded lip

CORE COLOR: H (fired in a reducing environment and cooled in the open air)

INTERIOR SURFACE COLOR: yellowish-brown; organic residue on the rim and body

EXTERIOR SURFACE COLOR: dark grayish-brown; fire clouds on the rim and body; organic residue on the body

WALL THICKNESS (IN MM): rim, 5.1 mm

INTERIOR SURFACE TREATMENT: none

EXTERIOR SURFACE TREATMENT: none

HEIGHT (IN CM): 10.2

ORIFICE DIAMETER (IN CM): 10.9

DIAMETER AT BOTTOM OF RIM OR NECK (IN CM): 9.5

BASE DIAMETER (IN CM) AND SHAPE OF BASE: 6.4 cm, circular and flat

ESTIMATED VOLUME (IN LITERS): 0.7

DECORATION (INCLUDING MOTIF AND ELEMENTS WHEN APPARENT): The rim has horizontal brushing marks. There are four applied nodes around the vessel at the rim-body juncture, and another set of four applied nodes on the lower vessel body.

PIGMENT USE AND LOCATION ON VESSEL: none

TYPE AND VARIETY (IF KNOWN): Unidentified utility ware

SITE NAME OR SITE NUMBER: Knight's Bluff (41CS14)

VESSEL NO.: 6991, Burial 2

VESSEL FORM: Jar

NON-PLASTICS AND PASTE: grog and bone

RIM AND LIP FORM: Everted rim and rounded lip; four small lip tabs

CORE COLOR: F (fired in a reducing environment and cooled in the open air)

INTERIOR SURFACE COLOR: reddish-brown; fire clouds on the rim and body

EXTERIOR SURFACE COLOR: reddish-brown; fire clouds on the rim and body

WALL THICKNESS (IN MM): rim, 4.9 mm

INTERIOR SURFACE TREATMENT: smoothed on the rim

EXTERIOR SURFACE TREATMENT: none

HEIGHT (IN CM): 9.6

ORIFICE DIAMETER (IN CM): 12.1

DIAMETER AT BOTTOM OF RIM OR NECK (IN CM): 9.6

BASE DIAMETER (IN CM) AND SHAPE OF BASE: 6.4 cm, circular and rounded

ESTIMATED VOLUME (IN LITERS): 0.7

DECORATION (INCLUDING MOTIF AND ELEMENTS WHEN APPARENT): The rim has two smoothed over neck banded rows. The vessel body has four sets of tool-punctated triangle elements defined by diagonal rows of tool punctations; these extend to the mid-body on the vessel. Each of the four punctated triangular elements are filled with rows of tool punctations.

PIGMENT USE AND LOCATION ON VESSEL: none

TYPE AND VARIETY (IF KNOWN): Nash Neck Banded, grog-tempered variety

SITE NAME OR SITE NUMBER: Knight's Bluff (41CS14)

VESSEL NO.: 6992, Burial 2

VESSEL FORM: Jar

NON-PLASTICS AND PASTE: grog and bone

RIM AND LIP FORM: Everted rim and rounded lip

CORE COLOR: G (fired in a reducing environment and cooled in the open air)

INTERIOR SURFACE COLOR: dark grayish-brown

EXTERIOR SURFACE COLOR: brown; fire clouds on the rim, body, and base

WALL THICKNESS (IN MM): rim, 6.2 mm

INTERIOR SURFACE TREATMENT: smoothed

EXTERIOR SURFACE TREATMENT: none

HEIGHT (IN CM): 8.3

ORIFICE DIAMETER (IN CM): 10.0

DIAMETER AT BOTTOM OF RIM OR NECK (IN CM): 7.7

BASE DIAMETER (IN CM) AND SHAPE OF BASE: 5.7 cm, circular and flat

ESTIMATED VOLUME (IN LITERS): 0.5

DECORATION (INCLUDING MOTIF AND ELEMENTS WHEN APPARENT): Two neck-banded rows on the rim have been smoothed over.

PIGMENT USE AND LOCATION ON VESSEL: none

TYPE AND VARIETY (IF KNOWN): Nash Neck Banded, grog-tempered variety



SITE NAME OR SITE NUMBER: Knight's Bluff (41CS14)

VESSEL NO.: 6993, Burial 2

VESSEL FORM: Bottle

NON-PLASTICS AND PASTE: grog

RIM AND LIP FORM: Direct rim and rounded lip

CORE COLOR: B (fired and cooled in a reducing environment)

INTERIOR SURFACE COLOR: very dark grayish-brown

EXTERIOR SURFACE COLOR: very dark grayish-brown; fire clouds on the body

WALL THICKNESS (IN MM): neck, 5.0 mm; base, 7.1 mm

INTERIOR SURFACE TREATMENT: none

EXTERIOR SURFACE TREATMENT: smoothed

HEIGHT (IN CM): 14.3

ORIFICE DIAMETER (IN CM): 3.2

DIAMETER AT BOTTOM OF RIM OR NECK (IN CM): 3.8; maximum body diameter: 9.0 cm

BASE DIAMETER (IN CM) AND SHAPE OF BASE: 5.4 cm, circular and flat

ESTIMATED VOLUME (IN LITERS):  
0.3

DECORATION (INCLUDING MOTIF AND ELEMENTS WHEN APPARENT):  
There are three horizontal engraved lines at the top and bottom of the vessel body; sets of large pendant triangles are appended to the lowermost horizontal engraved line at the top of the body (Figure 2). Between these lines are two rows of four or five concentric engraved circles and half-circles, as well as portions of two triangle elements.

PIGMENT USE AND LOCATION ON VESSEL: none

TYPE AND VARIETY (IF KNOWN):  
Antioch Engraved (Jelks 1961)

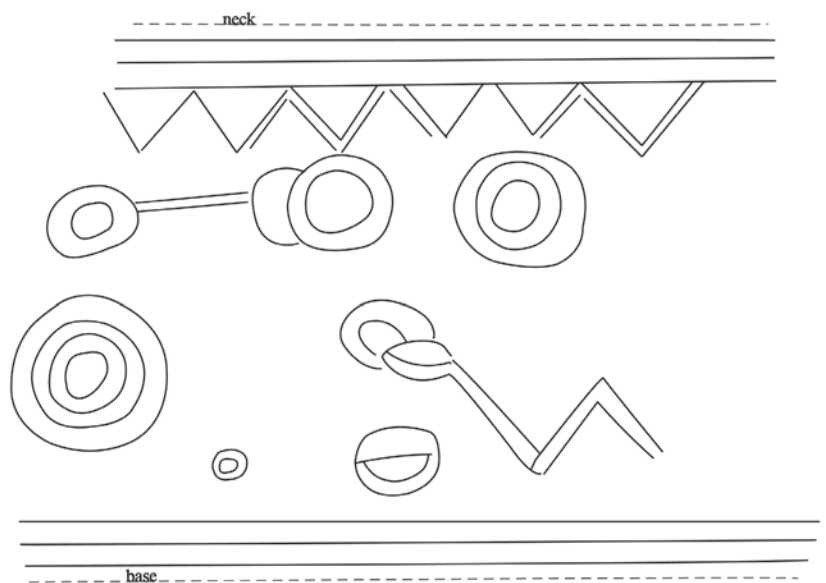

Figure 2. Decorative elements on Antioch Engraved bottle (No. 6993) in Burial 2 at the Knight's Bluff site.

SITE NAME OR SITE NUMBER: Knight's Bluff (41CS14)

VESSEL NO.: 6998, Burial 5

VESSEL FORM: Jar

NON-PLASTICS AND PASTE: grog

RIM AND LIP FORM: Everted rim and rounded lip

CORE COLOR: G (fired in a reducing environment and cooled in the open air)

INTERIOR SURFACE COLOR: dark grayish-brown

EXTERIOR SURFACE COLOR: yellowish-brown; fire clouds on the rim and body

WALL THICKNESS (IN MM): rim, 4.9 mm

INTERIOR SURFACE TREATMENT: none

EXTERIOR SURFACE TREATMENT: none

HEIGHT (IN CM): 15.0

ORIFICE DIAMETER (IN CM): 10.2

DIAMETER AT BOTTOM OF RIM OR NECK (IN CM): 8.8

BASE DIAMETER (IN CM) AND SHAPE OF BASE: 7.6 cm, circular and flat

ESTIMATED VOLUME (IN LITERS): 0.9

DECORATION (INCLUDING MOTIF AND ELEMENTS WHEN APPARENT): The rim has upper and lower diagonal opposed incised lines divided by a single horizontal row of small circular punctations (Figure 3). There is a single row of fingernail punctations at the rim-body juncture.

The vessel body is divided into four panels by vertical applied fillets (see Figure 3). The panels either have sets of incised lines oriented in different directions that are separated by either horizontal or vertical punctated rows, or have sets of incised lines oriented in different directions along with areas of vertical brushing. These incised or brushed areas are divided by horizontal and vertical punctated rows.

PIGMENT USE AND LOCATION ON VESSEL: none

TYPE AND VARIETY (IF KNOWN): Pease Brushed-Incised

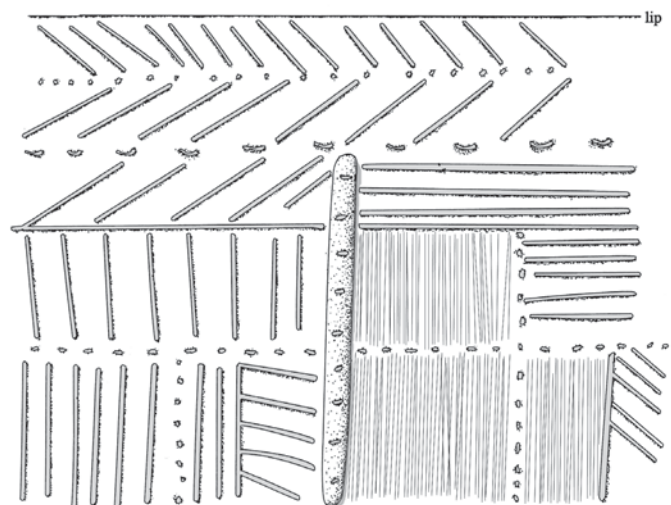

Figure 3. Decorative elements on Pease Brushed-Incised jar (No. 6998) in Burial 5 at the Knight's Bluff site.

SITE NAME OR SITE NUMBER: Knight's Bluff (41CS14)

VESSEL NO.: 6999, Burial 7

VESSEL FORM: Bottle

NON-PLASTICS AND PASTE: grog

RIM AND LIP FORM: Direct rim and rounded lip

CORE COLOR: B (fired and cooled in a reducing environment)

INTERIOR SURFACE COLOR: very dark gray

EXTERIOR SURFACE COLOR: very dark gray

WALL THICKNESS (IN MM): rim, 4.6 mm

INTERIOR SURFACE TREATMENT: none

EXTERIOR SURFACE TREATMENT: burnished

HEIGHT (IN CM): 12.7

ORIFICE DIAMETER (IN CM): 2.5

DIAMETER AT BOTTOM OF RIM OR NECK (IN CM): 2.9; maximum body diameter: 8.3 cm

BASE DIAMETER (IN CM) AND SHAPE OF BASE: 4.0 cm, circular and flat

ESTIMATED VOLUME (IN LITERS): 0.2

DECORATION (INCLUDING MOTIF AND ELEMENTS WHEN APPARENT): There are two horizontal engraved lines at the top of the vessel body, and a single horizontal engraved line above the vessel base. The remainder of the body has concentric circular and hooked arm elements that are surrounded and connected by hatched zones that are rectangular and triangular in shape (Figure 4). Several of the circular elements are connected by engraved bracket elements.

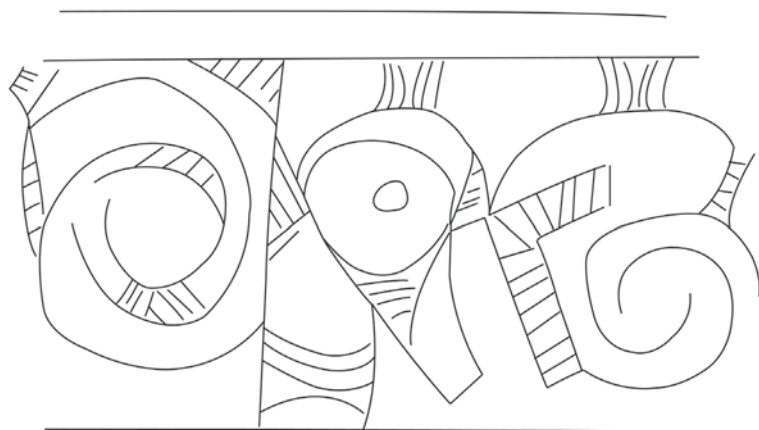

Figure 4. Decorative elements on Antioch Engraved bottle (No. 6999) in Burial 7 from the Knight's Bluff site.

PIGMENT USE AND LOCATION ON VESSEL: red pigment in the engraved lines

TYPE AND VARIETY (IF KNOWN): Antioch Engraved

SITE NAME OR SITE NUMBER: Knight's Bluff (41CS14)

VESSEL NO.: 7000, Burial 7

VESSEL FORM: Carinated bowl

NON-PLASTICS AND PASTE: grog

RIM AND LIP FORM: Direct rim and rounded lip

CORE COLOR: G (fired in a reducing environment and cooled in the open air)

INTERIOR SURFACE COLOR: dark grayish-brown

EXTERIOR SURFACE COLOR: reddish-brown; fire clouds on the rim, body, and base

WALL THICKNESS (IN MM): rim, 4.6 mm

INTERIOR SURFACE TREATMENT: smoothed

EXTERIOR SURFACE TREATMENT: burnished

HEIGHT (IN CM): 7.0

ORIFICE DIAMETER (IN CM): 14.0

DIAMETER AT BOTTOM OF RIM OR NECK (IN CM): 14.0

BASE DIAMETER (IN CM) AND SHAPE OF BASE: 7.6 cm, circular and rounded

ESTIMATED VOLUME (IN LITERS): 0.6

DECORATION (INCLUDING MOTIF AND ELEMENTS WHEN APPARENT): The rim panel has five sets of rectilinear engraved areas filled with cross-hatched engraved lines (Figure 5). The rectilinear areas outline negative horizontal scrolls.

PIGMENT USE AND LOCATION ON VESSEL: none

TYPE AND VARIETY (IF KNOWN): Friendship Engraved (Suhm and Jelks 1962:45)

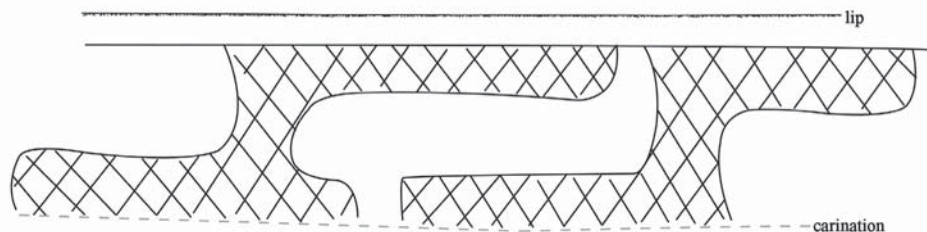

Figure 5. Decorative elements on Friendship Engraved carinated bowl (No. 7000) in Burial 7 at the Knight's Bluff site.

SITE NAME OR SITE NUMBER: Knight's Bluff (41CS14)

VESSEL NO.: 7001, Burial 9

VESSEL FORM: Bottle

NON-PLASTICS AND PASTE: grog

RIM AND LIP FORM: Direct rim and rounded lip

CORE COLOR: B (fired and cooled in a reducing environment)

INTERIOR SURFACE COLOR: very dark gray

EXTERIOR SURFACE COLOR: very dark gray; fire clouds on the rim

WALL THICKNESS (IN MM): rim, 4.5 mm

INTERIOR SURFACE TREATMENT: none

EXTERIOR SURFACE TREATMENT: burnished

HEIGHT (IN CM): 17.8

ORIFICE DIAMETER (IN CM): 4.4

DIAMETER AT BOTTOM OF RIM OR NECK (IN CM): 5.3; maximum body diameter: 13.2 cm

BASE DIAMETER (IN CM) AND SHAPE OF BASE: 8.2 cm, circular and flat

ESTIMATED VOLUME (IN LITERS): 0.5

DECORATION (INCLUDING MOTIF AND ELEMENTS WHEN APPARENT):

There is a narrow horizontal zone filled with cross-hatched engraved lines at the top of the vessel body, as well as two other horizontal engraved lines; there are three horizontal engraved lines at the bottom of the vessel body (Figure 6). The remainder of the vessel body has three sets of concentric engraved circles and circular cross-hatched zones, cross-hatched inner circles, and outer curvilinear and curvilinear cross-hatched engraved lines. These engraved sets are divided by three separate large cross-engraved bracket elements.

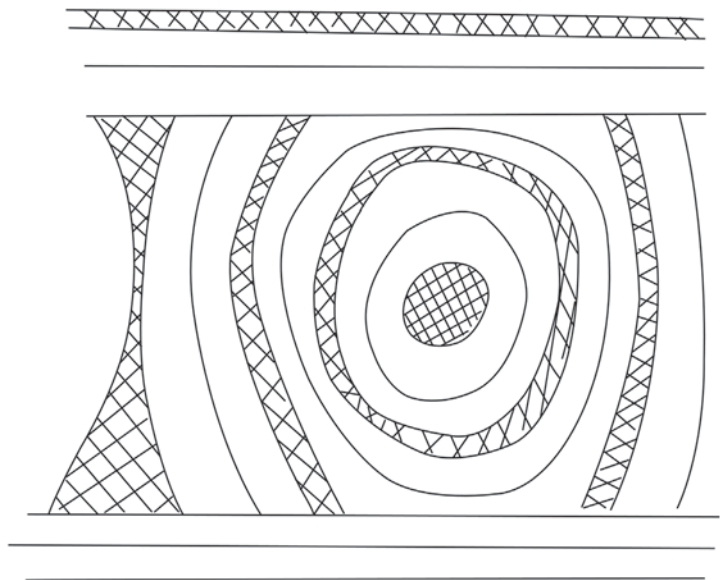

PIGMENT USE AND LOCATION ON VESSEL: none

Figure 6. Decorative elements on cf. Glassell Engraved bottle (No. 7001) in Burial 9 at the Knight's Bluff site.

TYPE AND VARIETY (IF KNOWN): cf. Glassell Engraved

SITE NAME OR SITE NUMBER: Knight's Bluff (41CS14)

VESSEL NO.: 7002, Burial 9

VESSEL FORM: Jar

NON-PLASTICS AND PASTE: grog and bone

RIM AND LIP FORM: Direct rim and rounded, exterior folded lip

CORE COLOR: J (sooted or smudged on both vessel surfaces)

INTERIOR SURFACE COLOR: very dark gray

EXTERIOR SURFACE COLOR: very dark gray; fire clouds on the rim, body, and base

WALL THICKNESS (IN MM): rim, 5.4 mm; body, 5.7 mm

INTERIOR SURFACE TREATMENT: smoothed

EXTERIOR SURFACE TREATMENT: none

HEIGHT (IN CM): 16.5

ORIFICE DIAMETER (IN CM): 13.6

DIAMETER AT BOTTOM OF RIM OR NECK (IN CM): 12.9

BASE DIAMETER (IN CM) AND SHAPE OF BASE: 8.2 cm, circular and flat

ESTIMATED VOLUME (IN LITERS): 1.4

DECORATION (INCLUDING MOTIF AND ELEMENTS WHEN APPARENT): The lip of the vessel is notched, and the rim has seven horizontal rows of tool punctations. The vessel body has four sets of continuous curvilinear applied fillets, and the zones between the fillets are filled with rows of linear tool punctations (Figure 7).

PIGMENT USE AND LOCATION ON VESSEL: none

TYPE AND VARIETY (IF KNOWN):  
Unidentified utility ware

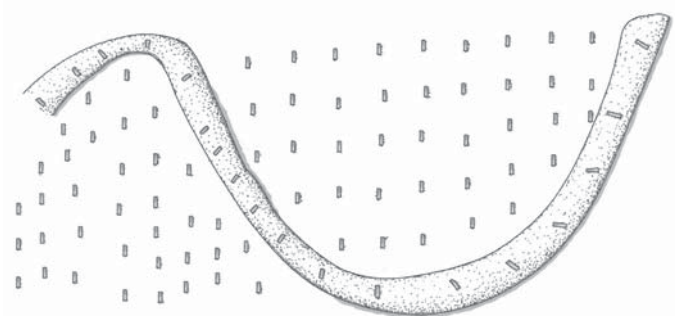

Figure 7. Decorative elements on the body of a utility ware jar (No. 7002) in Burial 9 at the Knight's Bluff site.

SITE NAME OR SITE NUMBER: Knight's Bluff (41CS14)

VESSEL NO.: 7003, Burial 10

VESSEL FORM: Bottle

NON-PLASTICS AND PASTE: grog

RIM AND LIP FORM: Direct rim and flat lip

CORE COLOR: G (fired in a reducing environment and cooled in the open air)

INTERIOR SURFACE COLOR: grayish-brown

EXTERIOR SURFACE COLOR: reddish-brown; fire clouds on the rim and body

WALL THICKNESS (IN MM): rim, 4.2 mm

INTERIOR SURFACE TREATMENT: none

EXTERIOR SURFACE TREATMENT: burnished

HEIGHT (IN CM): 15.5

ORIFICE DIAMETER (IN CM): 4.4

DIAMETER AT BOTTOM OF RIM OR NECK (IN CM): 5.8 cm; maximum body diameter: 12.7 cm

BASE DIAMETER (IN CM) AND SHAPE OF BASE: 8.3 cm, circular and flat

ESTIMATED VOLUME (IN LITERS): 0.5

DECORATION (INCLUDING MOTIF AND ELEMENTS WHEN APPARENT): There are three horizontal engraved lines at both the top and bottom of the vessel body; one line has negative pendant ovals outlined by narrow excised areas.

Between these lines are four sets of curvilinear and diagonal engraved lines that have a series of hatched spur elements (Figure 8). Dividing the four sets are single diagonal engraved lines with hatched and excised triangle elements and spurs as well as negative SZ elements outlined by excised areas.

PIGMENT USE AND LOCATION ON VESSEL: none

TYPE AND VARIETY (IF KNOWN):  
Haley Engraved

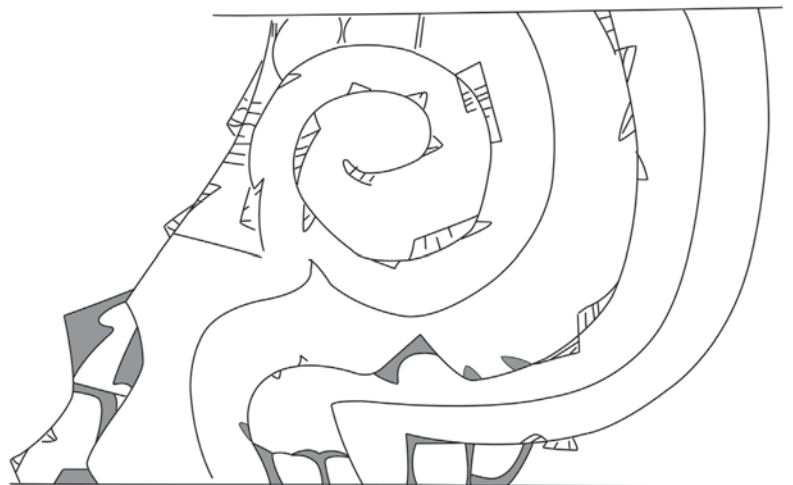

Figure 8. Decorative elements on a Haley Engraved bottle (No. 7003) in Burial 10 at the Knight's Bluff site.



SITE NAME OR SITE NUMBER: Knight's Bluff (41CS14)

VESSEL NO.: 7004, Burial 10

VESSEL FORM: Jar with four rim peaks

NON-PLASTICS AND PASTE: grog

RIM AND LIP FORM: Direct rim and rounded lip

CORE COLOR: F (fired in a reducing environment and cooled in the open air)

INTERIOR SURFACE COLOR: yellowish-brown; fire clouds on the rim and body

EXTERIOR SURFACE COLOR: yellowish-brown; fire clouds on the rim, body, and base

WALL THICKNESS (IN MM): rim, 7.2 mm

INTERIOR SURFACE TREATMENT: smoothed

EXTERIOR SURFACE TREATMENT: smoothed on the lowest part of the vessel body

HEIGHT (IN CM): 13.0; 14.0 cm at the rim peaks

ORIFICE DIAMETER (IN CM): 12.8

DIAMETER AT BOTTOM OF RIM OR NECK (IN CM): 12.8

BASE DIAMETER (IN CM) AND SHAPE OF BASE: 9.2 cm, circular and flat

ESTIMATED VOLUME (IN LITERS): 1.0

DECORATION (INCLUDING MOTIF AND ELEMENTS WHEN APPARENT):

The uppermost part of the rim, and including the rim peaks, is decorated with a single row of small punctations. The remainder of the rim has horizontal brushing marks, along with a row of tool punctations at the rim-body juncture (Figure 9). The vessel body is divided by four sets of curvilinear applied fillets, and the area above and below the fillets is filled with diagonal opposed or vertical brushing marks. Two of the sets have a single vertical row of small tool punctations pushed through the brushing marks.

PIGMENT USE AND LOCATION ON VESSEL: none

TYPE AND VARIETY (IF KNOWN):  
Pease Brushed-Incised

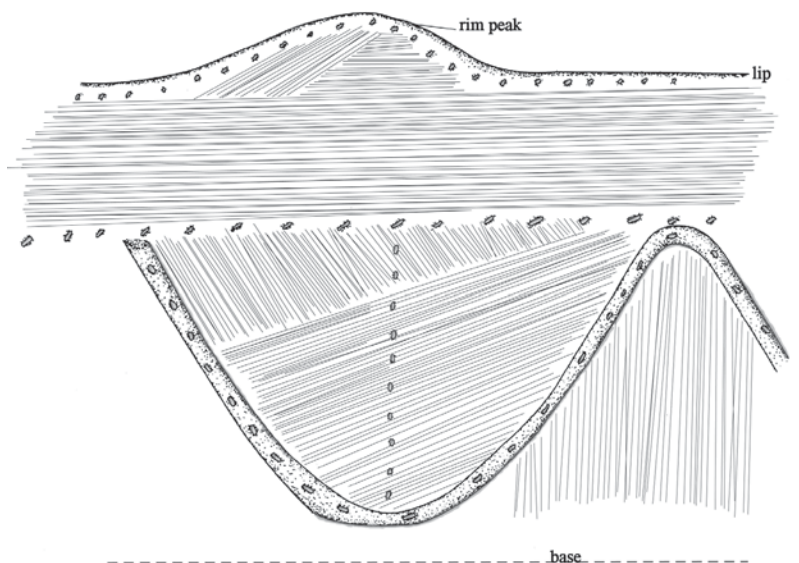

Figure 9. Decorative elements on a Pease Brushed-Incised jar (No. 7004) in Burial 10 at the Knight's Bluff site.



SITE NAME OR SITE NUMBER: Knight's Bluff (41CS14)

VESSEL NO.: 7005, Burial 11

VESSEL FORM: Bottle

NON-PLASTICS AND PASTE: grog

RIM AND LIP FORM: Direct rim and rounded lip

CORE COLOR: G (fired in a reducing environment and cooled in the open air)

INTERIOR SURFACE COLOR: grayish-brown

EXTERIOR SURFACE COLOR: dark reddish-brown

WALL THICKNESS (IN MM): rim, 5.0 mm

INTERIOR SURFACE TREATMENT: none

EXTERIOR SURFACE TREATMENT: burnished

HEIGHT (IN CM): 21.2

ORIFICE DIAMETER (IN CM): 5.1

DIAMETER AT BOTTOM OF RIM OR NECK (IN CM): 5.8; maximum body diameter: 14.0 cm

BASE DIAMETER (IN CM) AND SHAPE OF BASE: 8.4 cm, circular and flat

ESTIMATED VOLUME (IN LITERS): 0.7

DECORATION (INCLUDING MOTIF AND ELEMENTS WHEN APPARENT): The top and bottom of the vessel body have three horizontal engraved lines. The remainder of the vessel body has sets of engraved concentric circles, with one of the innermost circles having a series of excised spur elements (Figure 10). The outermost concentric circle has a series of engraved tick mark elements. The sets of engraved concentric circles are surrounded by oval-shaped areas with hooked arms as well as hatched and cross-hatched bracket-shaped and triangle-shaped areas, as well as semi-circles with ticked lines. The engraved concentric circle sets are divided by closely-spaced diagonal or curvilinear engraved lines with tick marks (Figure 10).

PIGMENT USE AND LOCATION ON VESSEL: none

TYPE AND VARIETY (IF KNOWN): cf. Haley Engraved

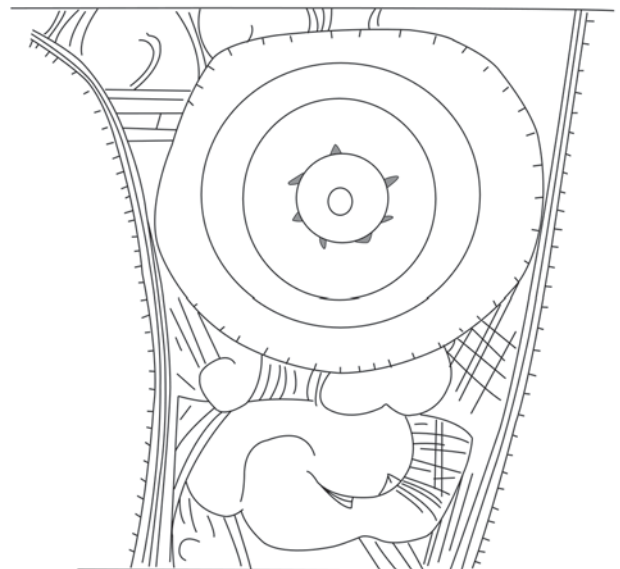

Figure 10. Decorative elements on a cf. Haley Engraved bottle (No. 7005) in Burial 11 at the Knight's Bluff site.

SITE NAME OR SITE NUMBER: Knight's Bluff (41CS14)

VESSEL NO.: 7006, Burial 11

VESSEL FORM: Jar

NON-PLASTICS AND PASTE: grog

RIM AND LIP FORM: Everted rim and rounded lip

CORE COLOR: B (fired and cooled in a reducing environment)

INTERIOR SURFACE COLOR: very dark grayish-brown

EXTERIOR SURFACE COLOR: very dark grayish-brown

WALL THICKNESS (IN MM): rim, 6.6 mm

INTERIOR SURFACE TREATMENT: smoothed

EXTERIOR SURFACE TREATMENT: none

HEIGHT (IN CM): 14.8

ORIFICE DIAMETER (IN CM): 12.7

DIAMETER AT BOTTOM OF RIM OR NECK (IN CM): 12.1

BASE DIAMETER (IN CM) AND SHAPE OF BASE: 8.9 cm, circular and flat

ESTIMATED VOLUME (IN LITERS): 1.1

DECORATION (INCLUDING MOTIF AND ELEMENTS WHEN APPARENT):

The rim has horizontal brushing marks as well as a row of small tool punctations at the lip and a second row at the rim-body juncture. The vessel body has sets of brushing marks oriented in several different directions in panels outlined by vertical, horizontal, curvilinear, and diagonal rows of tool punctations (Figure 11).

PIGMENT USE AND LOCATION ON VESSEL: none

TYPE AND VARIETY (IF KNOWN):  
Pease Brushed-Incised

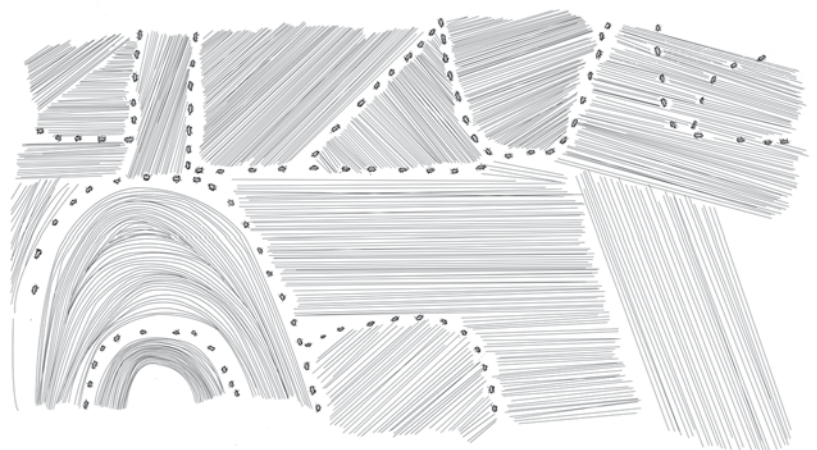

Figure 11. Decorative elements on the body of a Pease Brushed-Incised jar (No. 7006) in Burial 11 at the Knight's Bluff site.

SITE NAME OR SITE NUMBER: Knight's Bluff (41CS14)

VESSEL NO.: 7007, Burial 11

VESSEL FORM: Compound bowl

NON-PLASTICS AND PASTE: grog

RIM AND LIP FORM: Everted rim and rounded lip

CORE COLOR: G (fired in a reducing environment and cooled in the open air)

INTERIOR SURFACE COLOR: dark grayish-brown

EXTERIOR SURFACE COLOR: dark reddish-brown; fire clouds on the rim, body, and base

WALL THICKNESS (IN MM): rim, 4.9 mm

INTERIOR SURFACE TREATMENT: none

EXTERIOR SURFACE TREATMENT: smoothed

HEIGHT (IN CM): 8.9

ORIFICE DIAMETER (IN CM): 12.5

DIAMETER AT BOTTOM OF RIM OR NECK (IN CM): 9.9

BASE DIAMETER (IN CM) AND SHAPE OF BASE: 7.4 cm, circular and flat

ESTIMATED VOLUME (IN LITERS): 0.9

DECORATION (INCLUDING MOTIF AND ELEMENTS WHEN APPARENT): The upper panel of the vessel has three horizontal engraved lines; the central and middle engraved line has diagonal tick marks (Figure 12). The lower panel has four sets of horizontal-vertical scroll lines with closely-spaced engraved elements both above (i.e., brackets) and to the left of the scroll lines. The closely-spaced engraved elements left of the engraved scroll line comprise conjoined upper and lower bracket-shaped areas filled with curvilinear engraved lines.

PIGMENT USE AND LOCATION ON VESSEL: none

TYPE AND VARIETY (IF KNOWN): cf. Barkman Engraved (see Suhm and Jelks 1962:7)

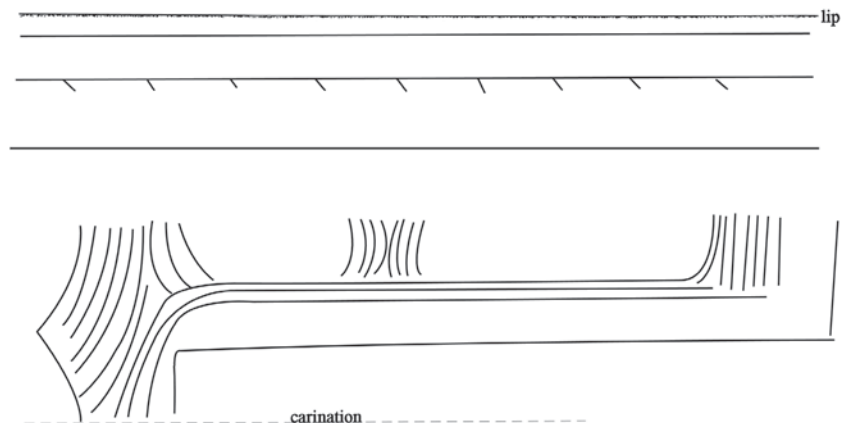

Figure 12. Decorative elements on cf. Barkman Engraved compound bowl (No. 7007) in Burial 11 at the Knight's Bluff site.

SITE NAME OR SITE NUMBER: Knight's Bluff (41CS14)

VESSEL NO.: 7008; not from a burial (Jelks 1961:76)

VESSEL FORM: Jar with four rim peaks and four applied lugs under the rim peaks

NON-PLASTICS AND PASTE: grog and bone

RIM AND LIP FORM: Everted rim and rounded lip

CORE COLOR: B (fired and cooled in a reducing environment)

INTERIOR SURFACE COLOR: dark grayish-brown

EXTERIOR SURFACE COLOR: dark grayish-brown; fire clouds on the body and base

WALL THICKNESS (IN MM): rim, 6.3 mm

INTERIOR SURFACE TREATMENT: smoothed

EXTERIOR SURFACE TREATMENT: smoothed only on the lower part of the vessel body

HEIGHT (IN CM): 14.0

ORIFICE DIAMETER (IN CM): 10.4

DIAMETER AT BOTTOM OF RIM OR NECK (IN CM): 9.0

BASE DIAMETER (IN CM) AND SHAPE OF BASE: 6.4 cm, circular and rounded

ESTIMATED VOLUME (IN LITERS): 0.9

DECORATION (INCLUDING MOTIF AND ELEMENTS WHEN APPARENT): The vessel rim has four horizontal rows of neck banding (see Jelks 1961:Plate 3d). The vessel body has closely-spaced vertical applied ridges that extend to within 3.4 cm of the base.

PIGMENT USE AND LOCATION ON VESSEL: none

TYPE AND VARIETY (IF KNOWN): Nash Neck Banded, grog-tempered variety

#### **Sherwin Site Vessels**

The Sherwin site was also occupied during the Middle Caddo period (ca. A.D. 1200-1400) (Cliff 1997). It is a habitation site with a large midden deposit (Jelks 1961:57) that had probably accumulated inside a structure. During Jelks' (1961:Figure 8) excavations at the Sherwin site, a total of eight prehistoric burials were excavated, six in a small cemetery at the northern end of the site and Burials 3 and 8 some distance to the south and southeast.

SITE NAME OR SITE NUMBER: Sherwin (41CS26)

VESSEL NO.: 2036, Burial 1

VESSEL FORM: Bottle

NON-PLASTICS AND PASTE: grog

RIM AND LIP FORM: Direct rim and rounded lip

CORE COLOR: B (fired and cooled in a reducing environment)

INTERIOR SURFACE COLOR: very dark grayish-brown

EXTERIOR SURFACE COLOR: very dark grayish-brown

WALL THICKNESS (IN MM): rim, 4.3 mm

INTERIOR SURFACE TREATMENT: none

EXTERIOR SURFACE TREATMENT: none

HEIGHT (IN CM): 10.9

ORIFICE DIAMETER (IN CM): 3.9

DIAMETER AT BOTTOM OF RIM OR NECK (IN CM): 4.0; maximum body diameter: 8.1 cm

BASE DIAMETER (IN CM) AND SHAPE OF BASE: 5.0 cm, circular and flat

ESTIMATED VOLUME (IN LITERS): 0.2

DECORATION (INCLUDING MOTIF AND ELEMENTS WHEN APPARENT): The uppermost part of the vessel body has two horizontal engraved lines. Pendant from the lowermost engraved line are five alternating sets of narrow vertical engraved bands and large pendant triangles (Figure 13). The vertical engraved bands are filled with diagonal or zig-zag engraved lines, while the pendant triangles have curvilinear hatched lines on two sides of the triangle and the third side has an excised triangular area (Figure 13).

PIGMENT USE AND LOCATION ON VESSEL:  
none

TYPE AND VARIETY (IF KNOWN): cf. Maddox  
Engraved

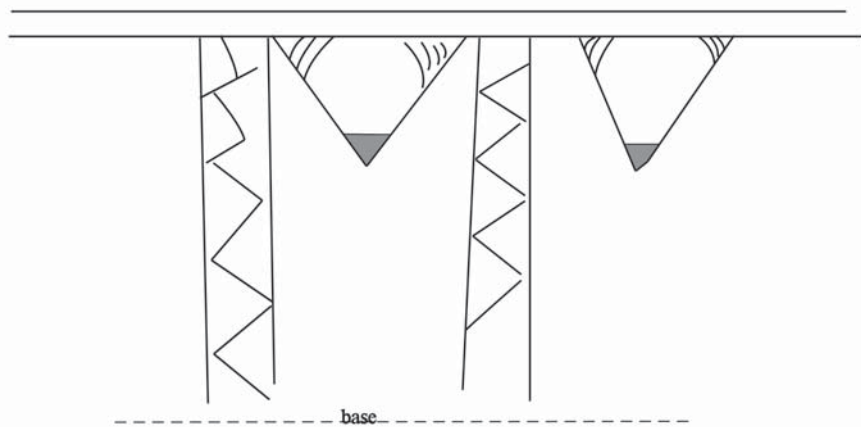

Figure 13. Decorative elements on cf. Maddox Engraved bottle (No. 2036) in Burial 1 at the Sherwin site.

SITE NAME OR SITE NUMBER: Sherwin

VESSEL NO.: 2037, Burial 1

VESSEL FORM: Jar

NON-PLASTICS AND PASTE: grog and bone

RIM AND LIP FORM: Everted rim and rounded lip

CORE COLOR: G (fired in a reducing environment and cooled in the open air)

INTERIOR SURFACE COLOR: dark grayish-brown

EXTERIOR SURFACE COLOR: reddish-brown; fire clouds on the rim, body, and base

WALL THICKNESS (IN MM): rim, 6.0 mm

INTERIOR SURFACE TREATMENT: smoothed only on the rim

EXTERIOR SURFACE TREATMENT: none

HEIGHT (IN CM): 17.7

ORIFICE DIAMETER (IN CM): 16.4

DIAMETER AT BOTTOM OF RIM OR NECK (IN CM): 14.8

BASE DIAMETER (IN CM) AND SHAPE OF BASE: 5.8 cm, circular and flat

ESTIMATED VOLUME (IN LITERS): 2.6

DECORATION (INCLUDING MOTIF AND ELEMENTS WHEN APPARENT): The rim has horizontal brushing marks. The vessel body has seven widely-spaced vertical rows of small tool punctations. The panels between the punctated rows have faint diagonal brushing marks.

PIGMENT USE AND LOCATION ON VESSEL: none

TYPE AND VARIETY (IF KNOWN): Pease Brushed-Incised

SITE NAME OR SITE NUMBER: Sherwin (41CS26)

VESSEL NO.: 2038, Burial 2

VESSEL FORM: Bottle

NON-PLASTICS AND PASTE: grog

RIM AND LIP FORM: Direct rim and rounded lip

CORE COLOR: A (fired and cooled in an oxidizing environment)

INTERIOR SURFACE COLOR: reddish-brown and yellowish-brown

EXTERIOR SURFACE COLOR: reddish-brown and yellowish-brown; fire clouds on the body and base

WALL THICKNESS (IN MM): rim, 5.0 mm

INTERIOR SURFACE TREATMENT: none

EXTERIOR SURFACE TREATMENT: none

HEIGHT (IN CM): 10.2

ORIFICE DIAMETER (IN CM): 2.8

DIAMETER AT BOTTOM OF RIM OR NECK (IN CM): 3.1; maximum body diameter: 8.3 cm

BASE DIAMETER (IN CM) AND SHAPE OF BASE: 6.7 cm, circular and flat

ESTIMATED VOLUME (IN LITERS): 0.3

DECORATION (INCLUDING MOTIF AND ELEMENTS WHEN APPARENT): The top of the vessel body has two horizontal engraved lines. There are 17 narrow vertical engraved zones or ladders that are filled with horizontal hatched lines that begin at the lowermost horizontal engraved line encircling the vessel body (Figure 14).

PIGMENT USE AND LOCATION ON VESSEL: none

TYPE AND VARIETY (IF KNOWN): cf. Maddox Engraved

SITE NAME OR SITE NUMBER: Sherwin (41CS26)

VESSEL NO.: 2053, Burial 2

VESSEL FORM: Jar

NON-PLASTICS AND PASTE: grog

RIM AND LIP FORM: Everted rim and rounded lip

CORE COLOR: G (fired in a reducing environment and cooled in the open air)

INTERIOR SURFACE COLOR: grayish-brown

EXTERIOR SURFACE COLOR: yellowish-brown; fire clouds on the body

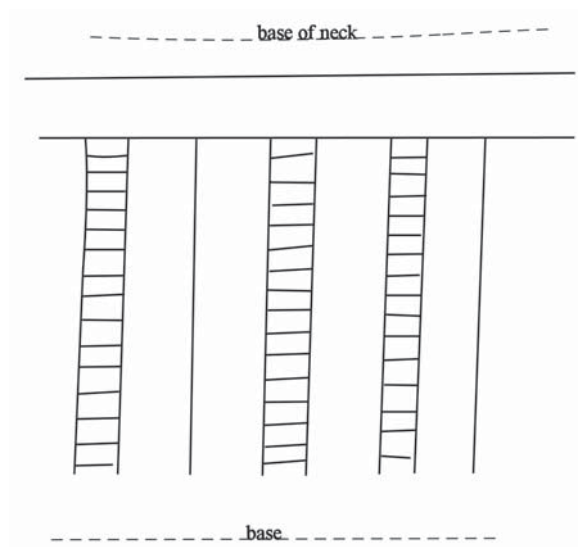

Figure 14. Decorative elements on cf. Maddox Engraved bottle (No. 2038) in Burial 2 at the Sherwin site.

WALL THICKNESS (IN MM): rim, 6.0 mm; body, 4.4 mm

INTERIOR SURFACE TREATMENT: none

EXTERIOR SURFACE TREATMENT: none

HEIGHT (IN CM): N/A

ORIFICE DIAMETER (IN CM): 13.4

DIAMETER AT BOTTOM OF RIM OR NECK (IN CM): 12.6

BASE DIAMETER (IN CM) AND SHAPE OF BASE: N/A

ESTIMATED VOLUME (IN LITERS): N/A

DECORATION (INCLUDING MOTIF AND ELEMENTS WHEN APPARENT): There are three horizontal rows of tool punctations on the rim. The vessel body has four vertical rows of widely-spaced appliqued nodes, with diagonal brushing marks in panels between the rows of appliqued nodes.

PIGMENT USE AND LOCATION ON VESSEL: none

TYPE AND VARIETY (IF KNOWN): cf. Pease Brushed-Incised

SITE NAME OR SITE NUMBER: Sherwin (41CS26)

VESSEL NO.: 2039, Burial 3

VESSEL FORM: Jar with four appliqued lip tabs

NON-PLASTICS AND PASTE: grog

RIM AND LIP FORM: Everted rim and rounded lip

CORE COLOR: G (fired in a reducing environment and cooled in the open air)

INTERIOR SURFACE COLOR: very dark grayish-brown

EXTERIOR SURFACE COLOR: yellowish-brown; fire clouds on the rim, body, and base; organic remains on the body

WALL THICKNESS (IN MM): rim, 6.4 mm

INTERIOR SURFACE TREATMENT: none

EXTERIOR SURFACE TREATMENT: none

HEIGHT (IN CM): 12.0

ORIFICE DIAMETER (IN CM): 11.3

DIAMETER AT BOTTOM OF RIM OR NECK (IN CM): 10.4



BASE DIAMETER (IN CM) AND SHAPE OF BASE: 7.6 cm, circular and flat

ESTIMATED VOLUME (IN LITERS): 0.8

DECORATION (INCLUDING MOTIF AND ELEMENTS WHEN APPARENT): The rim has three horizontal rows of neck bands as well as four vertical appliqued ridges that begin under each of the lip tabs. These vertical appliqued ridges continue onto the vessel body and extend to within 1.3 cm of the base.

PIGMENT USE AND LOCATION ON VESSEL: none

TYPE AND VARIETY (IF KNOWN): Nash Neck Banded, grog-tempered variety

SITE NAME OR SITE NUMBER: Sherwin (41CS26)

VESSEL NO.: 2040, Burial 3

VESSEL FORM: Bowl with two opposed lip tabs

NON-PLASTICS AND PASTE: grog and bone

RIM AND LIP FORM: Direct rim and rounded lip

CORE COLOR: F (fired in a reducing environment and cooled in the open air)

INTERIOR SURFACE COLOR: brown; fire clouds on the base

EXTERIOR SURFACE COLOR: brown; fire clouds on the body and base

WALL THICKNESS (IN MM): rim, 4.3 mm

INTERIOR SURFACE TREATMENT: smoothed

EXTERIOR SURFACE TREATMENT: burnished

HEIGHT (IN CM): 3.7

ORIFICE DIAMETER (IN CM): 11.4

DIAMETER AT BOTTOM OF RIM OR NECK (IN CM): N/A

BASE DIAMETER (IN CM) AND SHAPE OF BASE: 6.4 cm, circular and rounded

ESTIMATED VOLUME (IN LITERS): 0.2

DECORATION (INCLUDING MOTIF AND ELEMENTS WHEN APPARENT): Plain

PIGMENT USE AND LOCATION ON VESSEL: none

TYPE AND VARIETY (IF KNOWN): Unidentified plain ware

SITE NAME OR SITE NUMBER: Sherwin (41CS26)

VESSEL NO.: 2048, Burial 7

VESSEL FORM: Bottle

NON-PLASTICS AND PASTE: grog and bone

RIM AND LIP FORM: Direct rim and rounded lip

CORE COLOR: F (fired in a reducing environment and cooled in the open air)

INTERIOR SURFACE COLOR: red

EXTERIOR SURFACE COLOR: red

WALL THICKNESS (IN MM): rim, 6.5 mm

INTERIOR SURFACE TREATMENT: none

EXTERIOR SURFACE TREATMENT: burnished

HEIGHT (IN CM): 18.4

ORIFICE DIAMETER (IN CM): 3.7

DIAMETER AT BOTTOM OF RIM OR NECK (IN CM): 4.9; maximum body diameter: 12.3 cm

BASE DIAMETER (IN CM) AND SHAPE OF BASE: 7.2 cm, circular and rounded

ESTIMATED VOLUME (IN LITERS): 0.5

DECORATION (INCLUDING MOTIF AND ELEMENTS WHEN APPARENT): The vessel has a red slip on its exterior surface, as well as on the interior surface of the neck. Cut into the red slip on the exterior surface are three horizontal engraved lines at the top of the vessel body. Below the engraved lines are four sets of horizontal, concentric, and curvilinear engraved lines that end in a single hooked arm element (Figure 15). Dividing these four sets of engraved lines are large bracket-shaped elements with hatched triangle elements at the top of the bracket, and diagonal and diagonal opposed engraved lines at the mid-section of each bracket (Figure 15).

PIGMENT USE AND LOCATION ON VESSEL: none

TYPE AND VARIETY (IF KNOWN): cf. Haley Engraved

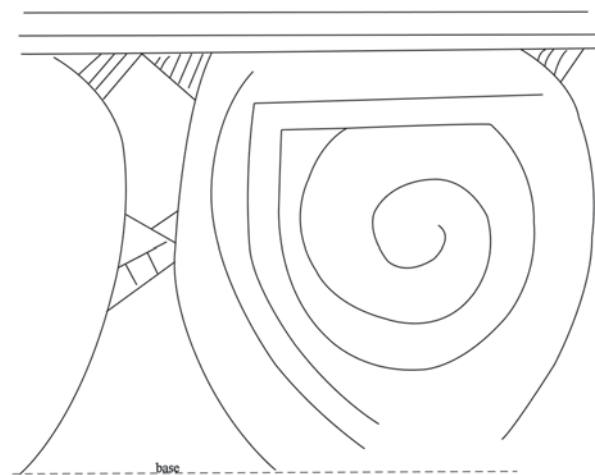

Figure 15. Decorative elements on cf. Haley Engraved bottle (No. 2048) in Burial 7 at the Sherwin site.

SITE NAME OR SITE NUMBER: Sherwin (41CS26)

VESSEL NO.: 2049, Burial 7

VESSEL FORM: Jar

NON-PLASTICS AND PASTE: grog and hematite

RIM AND LIP FORM: Everted rim and rounded lip

CORE COLOR: F (fired in a reducing environment and cooled in the open air)

INTERIOR SURFACE COLOR: reddish-brown; fire clouds on the rim and body

EXTERIOR SURFACE COLOR: reddish-brown; fire clouds on the rim, body, and base

WALL THICKNESS (IN MM): rim, 6.5 mm

INTERIOR SURFACE TREATMENT: smoothed

EXTERIOR SURFACE TREATMENT: none; the surface of the vessel is bubbly and semi-vitreous, suggesting that the vessel had been exposed to fire or re-fired before it was placed in the burial feature.

HEIGHT (IN CM): 15.8

ORIFICE DIAMETER (IN CM): 15.2

DIAMETER AT BOTTOM OF RIM OR NECK (IN CM): 14.4

BASE DIAMETER (IN CM) AND SHAPE OF BASE: 7.4 cm, circular and flat

ESTIMATED VOLUME (IN LITERS): 1.4

DECORATION (INCLUDING MOTIF AND ELEMENTS WHEN APPARENT): The rim of the vessel is plain, but there are four vertical rows of widely-spaced applied ridges on the vessel body.

PIGMENT USE AND LOCATION ON VESSEL: none

TYPE AND VARIETY (IF KNOWN): Unidentified utility ware

SITE NAME OR SITE NUMBER: Sherwin (41CS26)

VESSEL NO.: 2050, Burial 8

VESSEL FORM: Carinated bowl

NON-PLASTICS AND PASTE: grog

RIM AND LIP FORM: Direct rim and rounded lip

CORE COLOR: G (fired in a reducing environment and cooled in the open air)

INTERIOR SURFACE COLOR: black

EXTERIOR SURFACE COLOR: yellowish-brown; fire clouds on the rim, body, and base

WALL THICKNESS (IN MM): rim, 5.1 mm

INTERIOR SURFACE TREATMENT: smoothed

EXTERIOR SURFACE TREATMENT: smoothed

HEIGHT (IN CM): 6.4

ORIFICE DIAMETER (IN CM): 13.2

DIAMETER AT BOTTOM OF RIM OR NECK (IN CM): 13.2

BASE DIAMETER (IN CM) AND SHAPE OF BASE: 6.4 cm, circular and flat

ESTIMATED VOLUME (IN LITERS): 0.5

DECORATION (INCLUDING MOTIF AND ELEMENTS WHEN APPARENT): The rim panel has three horizontal incised lines at the top of the panel as well as a series of upper and lower triangular incised elements filled with diagonal incised lines (Figure 16). The triangles form upper and lower zones above a continuous negative scroll around the vessel. A very similar vessel has been recovered in Middle Caddo period contexts in Burial 3 at the Paul Mitchell site (41BW4) on Red River (Perttula et al. 2016:Figure 12a-b).

PIGMENT USE AND LOCATION ON VESSEL: none

TYPE AND VARIETY (IF KNOWN): Unidentified utility ware

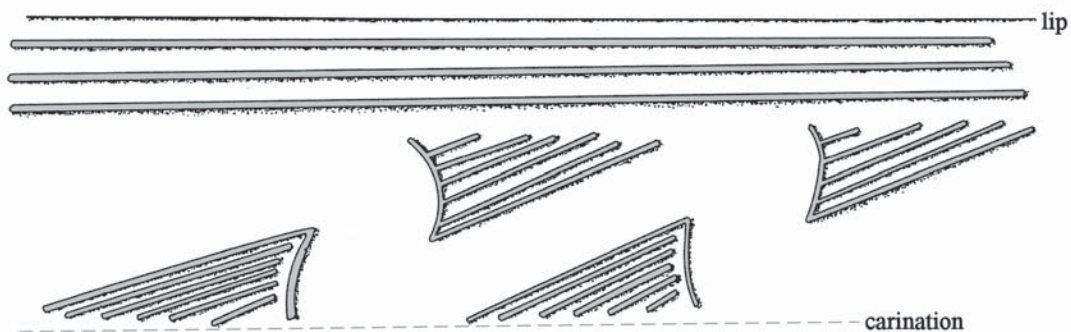

Figure 16. Decorative elements on incised carinated bowl (No. 2050) in Burial 8 at the Sherwin site.

SITE NAME OR SITE NUMBER: Sherwin (41CS26)

VESSEL NO.: 2051, Burial 8

VESSEL FORM: Bottle

NON-PLASTICS AND PASTE: grog

RIM AND LIP FORM: Direct rim and rounded lip

CORE COLOR: B (fired and cooled in a reducing environment)

INTERIOR SURFACE COLOR: dark grayish-brown

EXTERIOR SURFACE COLOR: dark brown; fire clouds on the rim and body

WALL THICKNESS (IN MM): rim, 5.3 mm

INTERIOR SURFACE TREATMENT: none

EXTERIOR SURFACE TREATMENT: burnished

HEIGHT (IN CM): 17.8

ORIFICE DIAMETER (IN CM): 4.0

DIAMETER AT BOTTOM OF RIM OR NECK (IN CM): 4.8; maximum body diameter: 10.1 cm

BASE DIAMETER (IN CM) AND SHAPE OF BASE: 7.0 cm, circular and flat

ESTIMATED VOLUME (IN LITERS): 0.5

DECORATION (INCLUDING MOTIF AND ELEMENTS WHEN APPARENT): The top of the vessel body has three horizontal engraved lines. The bottom horizontal line has 10 excised pendant triangles with their apexes pointing downward (Figure 17).

PIGMENT USE AND LOCATION ON VESSEL: none

TYPE AND VARIETY (IF KNOWN): Higgins Engraved (see Jelks 1961:61)

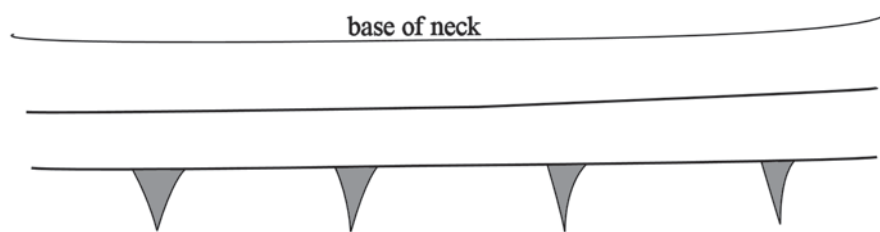

Figure 17. Decorative elements on a Higgins Engraved bottle (No. 2051) in Burial 8 at the Sherwin site.

SITE NAME OR SITE NUMBER: Sherwin (41CS26)

VESSEL NO.: 2052, Burial 8

VESSEL FORM: Bottle

NON-PLASTICS AND PASTE: grog

RIM AND LIP FORM: Direct rim and rounded lip

CORE COLOR: G (fired in a reducing environment and cooled in the open air)

INTERIOR SURFACE COLOR: dark grayish-brown

EXTERIOR SURFACE COLOR: yellowish-brown; fire clouds on the rim, body, and base

WALL THICKNESS (IN MM): rim, 5.7 mm

INTERIOR SURFACE TREATMENT: none

EXTERIOR SURFACE TREATMENT: burnished

HEIGHT (IN CM): 19.0

ORIFICE DIAMETER (IN CM): 4.5

DIAMETER AT BOTTOM OF RIM OR NECK (IN CM): 5.3

BASE DIAMETER (IN CM) AND SHAPE OF BASE: 6.8 cm, circular and flat

ESTIMATED VOLUME (IN LITERS): 0.5

DECORATION (INCLUDING MOTIF AND ELEMENTS WHEN APPARENT): The top of the vessel body has two horizontal engraved lines. Pendant from the bottom line are a series of large excised triangles that encircle the vessel (Figure 18).

PIGMENT USE AND LOCATION ON VESSEL: none

TYPE AND VARIETY (IF KNOWN): Higgins Engraved

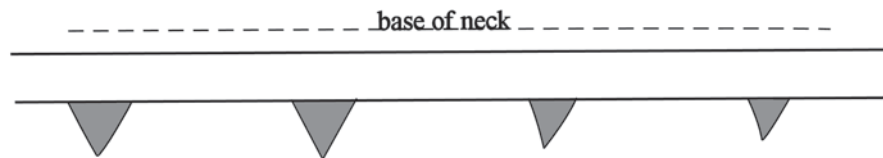

Figure 18. Decorative elements on a Higgins Engraved bottle (No. 2052) in Burial 8 at the Sherwin site.

SITE NAME OR SITE NUMBER: Sherwin (41CS26)

VESSEL NO.: X-1/Lot 1692

VESSEL FORM: Jar, lower body and base

NON-PLASTICS AND PASTE: grog

RIM AND LIP FORM: N/A

CORE COLOR: B (fired and cooled in a reducing environment)

INTERIOR SURFACE COLOR: dark gray

EXTERIOR SURFACE COLOR: very dark gray; fire clouds on the body

WALL THICKNESS (IN MM): body, 6.2 mm

INTERIOR SURFACE TREATMENT: none

EXTERIOR SURFACE TREATMENT: none

HEIGHT (IN CM): N/A

ORIFICE DIAMETER (IN CM): N/A

DIAMETER AT BOTTOM OF RIM OR NECK (IN CM): 12.7 cm at lower body

BASE DIAMETER (IN CM) AND SHAPE OF BASE: 6.7 cm, circular and flat

ESTIMATED VOLUME (IN LITERS): N/A

DECORATION (INCLUDING MOTIF AND ELEMENTS WHEN APPARENT): Plain

PIGMENT USE AND LOCATION ON VESSEL: none

TYPE AND VARIETY (IF KNOWN): Unidentified plain ware

SITE NAME OR SITE NUMBER: Sherwin (41CS26)

VESSEL NO.: X-2/Lots 653-654

VESSEL FORM: Jar, lower body and base

NON-PLASTICS AND PASTE: grog

RIM AND LIP FORM: N/A

CORE COLOR: G (fired in a reducing environment and cooled in the open air)

INTERIOR SURFACE COLOR: dark grayish-brown

EXTERIOR SURFACE COLOR: reddish-brown; fire clouds on the body and base

WALL THICKNESS (IN MM): body, 6.4 mm

INTERIOR SURFACE TREATMENT: smoothed

EXTERIOR SURFACE TREATMENT: none

HEIGHT (IN CM): N/A

ORIFICE DIAMETER (IN CM): N/A

DIAMETER AT BOTTOM OF RIM OR NECK (IN CM): 14.6 cm at the lower body

BASE DIAMETER (IN CM) AND SHAPE OF BASE: 8.9 cm, circular and flat

ESTIMATED VOLUME (IN LITERS): N/A

DECORATION (INCLUDING MOTIF AND ELEMENTS WHEN APPARENT): The vessel body has four widely-spaced vertical applied fillets. The panels between the fillets have diagonal incised lines pitched in opposite directions (Figure 19).

PIGMENT USE AND LOCATION ON VESSEL: none

TYPE AND VARIETY (IF KNOWN): Pease Brushed-Incised

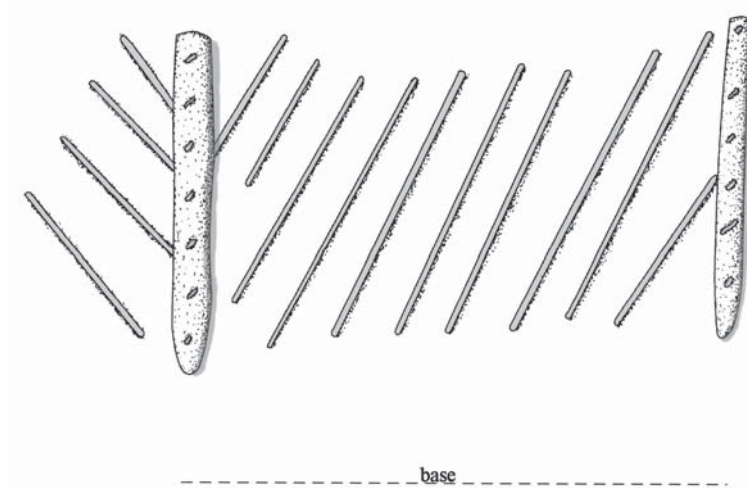

Figure 19. Decorative elements on Pease Brushed-Incised jar (X-2) from the Sherwin site.

#### **Vessel from Uncertain Context at either the Knight's Bluff or Sherwin Sites**

A section of one vessel is in the Lake Wright Patman collections at TARL, but it is uncertain, based on the vessel label, if the vessel is from the Knight's Bluff or Sherwin sites.

SITE NAME OR SITE NUMBER: Knight's Bluff or Sherwin

VESSEL NO.: 41-20D5-15/Lot 5763

VESSEL FORM: Jar, lower body and base

NON-PLASTICS AND PASTE: grog

RIM AND LIP FORM: N/A

CORE COLOR: G (fired in a reducing environment and cooled in the open air)

INTERIOR SURFACE COLOR: dark grayish-brown

EXTERIOR SURFACE COLOR: brown; fire clouds on the body and base

WALL THICKNESS (IN MM): body, 6.9 mm

INTERIOR SURFACE TREATMENT: smoothed



EXTERIOR SURFACE TREATMENT: smoothed

HEIGHT (IN CM): N/A

ORIFICE DIAMETER (IN CM): N/A

DIAMETER AT BOTTOM OF RIM OR NECK (IN CM): 16.9 cm at the mid-body

BASE DIAMETER (IN CM) AND SHAPE OF BASE: 8.0 cm, circular and rounded

ESTIMATED VOLUME (IN LITERS): N/A

DECORATION (INCLUDING MOTIF AND ELEMENTS WHEN APPARENT): The vessel body has four vertical rows of widely-spaced appliqued nodes.

PIGMENT USE AND LOCATION ON VESSEL: none

TYPE AND VARIETY (IF KNOWN): Unidentified utility ware

### Summary and Conclusions

There are 39 ancestral Caddo ceramic vessels from the Knight’s Bluff (41CS14) and Sherwin (41CS26) sites in the TARL collections, almost all from burial features in Middle Caddo period (ca. A.D. 1200-1400) family cemeteries. Nine of these vessels had been previously documented by Perttula et al. (2009) as part of a NAGPRA grant awarded to the Caddo Nation of Oklahoma, and the remainder have been documented in this article.

The proportion of vessel forms at the Knight’s Bluff and Sherwin sites is virtually identical (Table 1). More than 53 percent of the vessels from the two sites are jars, and another 31 percent are bottles. Only 7.7 percent of the vessels are carinated bowls, and the remainder are bowls (5.1 percent) and compound bowls (2.6 percent).

**Table 1. Forms of the vessels from the Knight’s Bluff and Sherwin sites in Cass County, Texas.**

Vessel Form	41CS14	41CS26	41CS14 or 26	N
Jar	10	10	1	21
Bowl	1	1	-	2
Bottle	6	6	-	12
Carinated bowl	1	2	-	3
Compound bowl	1	-	-	1
Totals	19	19	1	39

The vessels from both sites are tempered with grog or crushed sherds (Table 2). About 67 percent of the vessels are tempered solely with grog, and 26 percent have also had burned bone added as an aplastic: 21 percent of the Knight’s Bluff vessels and 33 percent of the Sherwin vessels. About five percent of the vessels, both from the Sherwin site, are tempered with grog and crushed pieces of hematite.

**Table 2. Temper used in the vessels from the Knight's Bluff and Sherwin sites.**

Temper	41CS14	41CS26	41CS14 or 26	N
grog	15	10	1	26
grog and bone	4	6	-	10
grog and hematite	-	2	-	2
Totals	19	18*	1	38

\*the temper could not be determined for one vessel

The vessels from the two sites were primarily fired in a reducing or low oxygen environment but cooled in the open air (Table 3): 65 percent of the vessels were fired in this manner, which is a traditional ancestral Caddo firing practice (see Perttula 2013:203-204). Another 24 percent were fired and cooled in a low oxygen or reducing environment, 5.4 percent were fired in an oxidizing environment or incompletely oxidized environment, and one vessel from the Knight's Bluff has been sooted or deliberately smudged.

**Table 3. Firing conditions for the vessels from the Knight's Bluff and Sherwin sites.**

Firing Conditions	41CS14	41CS26	41CS14 or 26	N
oxidizing	-	1	-	1
incompletely oxidized	-	1	-	1
reducing	5	4	-	9
reducing-cooled in open air	12	11	1	24
sooted/smudged	1	-	-	1
Totals	18	18	1	37*

\*firing conditions could not be determined for two vessels from the sites

Approximately 10 percent of the vessels at the Knight's Bluff and Sherwin are plain ware vessels (n=4), one vessel at Knight's Bluff and three vessels in the Sherwin site assemblage. Utility wares (i.e., vessels with wet paste decorations, including brushing, incised lines, punctations, etc.) comprise about 54 percent of the vessel assemblage, and these are primarily jars, but one vessel from the Sherwin site is a carinated bowl with incised decorative elements (see Figure 16). The principal utility wares at both sites are Pease Brushed-Incised (n=8 vessels) and a grog-tempered or early variety of Nash Neck Banded (n=6). Other utility wares have appliqued (n=2), brushed-appliqued decorative elements (n=1), brushed-punctated decorative elements (n=1), tool punctated rows (n=1), and punctated-appliqued decorative elements (n=1).

Among the fine wares (i.e., vessels with engraved and/or slipped decorative elements) at the site, the engraved vessels are primarily bottles of Haley Engraved (n=4), Antioch Engraved (see Jelks 1961) (n=3), Higgins Engraved (n=2), and cf. Maddox Engraved (n=2) types. Other fine wares include a Friendship Engraved carinated bowl from Knight's Bluff, a Glassell Engraved bottle from Burial 9 at Knight's Bluff, and a Barkman Engraved compound bowl from Burial 11 at Knight's Bluff. There are stylistic similarities in the engraved fine wares from the Knight's Bluff and Sherwin sites and the Middle Caddo period vessels from the Paul Mitchell site (41BW4) on the Red River (see Perttula et al. 2016:10-24, 28-34).

### Acknowledgments

Thanks to the staff at the Texas Archeological Research Laboratory at The University of Texas at Austin for providing access to their Lake Wright Patman vessel collections. Lance Trask prepared the figures in this article.

### References Cited

- Brown, J. A.  
1996 *The Spiro Ceremonial Center: The Archaeology of Arkansas Valley Caddoan Culture in Eastern Oklahoma*. 2 Vols. Memoirs No. 29. Museum of Anthropology, The University of Michigan, Ann Arbor.
- Cliff, M. B.  
1997 The Middle Caddoan Period in the Lower Sulphur River Area. *Journal of Northeast Texas Archaeology* 9:9-16.
- Ferring, C. R. and T. K. Perttula  
1987 Defining the Provenance of Red-Slipped Pottery from Texas and Oklahoma by Petrographic Methods. *Journal of Archaeological Science* 14:437-456.
- Fields, R. C., V. L. Hatfield, D. Burden, E. F. Gadus, M. C. Wilder, and K. W. Kibler  
2014 *Testing and Data Recovery Excavations at 11 Native American Archeological Sites along the U.S. Highway 271 Mount Pleasant Relief Route, Titus County, Texas*. 2 Vols. Reports of Investigations No. 168. Prewitt and Associates, Inc., Austin.
- Jelks, E. B.  
1961 *Excavations at Texarkana Reservoir, Sulphur River, Texas*. River Basin Surveys Papers No. 21, Bureau of Ethnology Bulletin 179. Smithsonian Institution, Washington, D.C.
- Perttula, T. K.  
1998 Caddo Ceramics from the Middle Caddoan Period Knight's Bluff Site (41CS14), Cass County, Texas. *Caddoan Archeology* 8(4):11-19.  
2013 Caddo Ceramics in East Texas. *Bulletin of the Texas Archeological Society* 84:181-212.
- Perttula, T. K. and R. Z. Selden Jr.  
2014 Ancestral Caddo Ceramics in East Texas. *Journal of Northeast Texas Archaeology* 48:9-58.
- Perttula, T. K., R. Cast, B. Gonzalez, and B. Nelson  
2009 *Documentation of Unassociated and Culturally Unidentifiable Funerary Objects in the U.S. Army Corps of Engineers, Fort Worth District Collections Housed at the Texas Archeological Research Laboratory at the University of Texas at Austin*. Special Publication No. 13. Friends of Northeast Texas Archaeology, Pittsburg and Austin.
- Perttula, T. K., B. Nelson, and M. Walters  
2016 *Caddo Ceramic Vessels from the Paul Mitchell Site (41BW4) on the Red River, Bowie County, Texas*. Special Publication No. 44. Friends of Northeast Texas Archaeology, Austin and Pittsburg.
- Rice, P. M.  
1987 *Pottery Analysis: A Sourcebook*. University of Chicago Press, Chicago.
- Schambach, F. F. and J. E. Miller  
1984 A Description and Analysis of the Ceramics. In *Cedar Grove: An Interdisciplinary Investigation of a Late Caddo Farmstead in the Red River Valley*, edited by N. L. Trubowitz, pp. 109-170. Research Series No. 23. Arkansas Archeological Survey, Fayetteville.

Skibo, J. M.

1992 *Pottery Function: A Use-Alteration Perspective*. Plenum Press, New York.

Suhm, D. A. and E. B. Jelks (editors)

1962 *Handbook of Texas Archeology: Type Descriptions*. Special Publication No. 1, Texas Archeological Society, and Bulletin No. 4, Texas Memorial Museum, Austin.

Teltser, P. A.

1993 An Analytic Strategy for Studying Assemblage-Scale Ceramic Variation: A Case Study from Southeast Missouri. *American Antiquity* 58(3):530-543.